

Table of contents

Introduction	2
Diesel information	4
Warning lights	9
Starting	12
Driving tips	15
General maintenance information	30
Scheduled maintenance	49
Minor troubleshooting guide	50
Capacities and specifications	53
Service points	55

All rights reserved. Reproduction by any means, electronic or mechanical including photocopying, recording or by any information storage and retrieval system or translation in whole or part is not permitted without written authorization from Ford Motor Company. Ford may change the contents without notice and without incurring obligation.

Introduction

The following warning may be required by California law:



California Proposition 65 Warning: Diesel engine exhaust, some of its constituents, and certain vehicle components contain or may emit chemicals known to the State of California to cause cancer or birth defects or other reproductive harm.

Your new diesel engine will feel, drive and function somewhat differently than a gasoline engine. Therefore it is very important that you read and thoroughly familiarize yourself and others operating the vehicle with this guide.

This guide will acquaint you with the Power Stroke (7.3L DIT) diesel engine. It provides recommendations on engine care and operating procedures. For complete vehicle information, also refer to the Owner Guide included with the vehicle. It also describes equipment and gives specifications for equipment that was in effect when this guide was approved for printing, and should be considered a permanent part of the vehicle.

Some aftermarket products may cause severe engine and/or transmission damage. There are various manufacturers offering devices to increase turbocharger boost, exhaust brakes to increase stopping/hauling capacity or other such devices to increase the power/torque of the 7.3L engine. Many owners' past experience with these products has been very poor. Severe powertrain damage may result from the use of these aftermarket products which will not be covered by the Ford warranty.

Ford may discontinue models or change specifications without any notice and without incurring obligations.

IMPORTANT NOTICE

Ford vehicles are suitable for producing ambulances only if equipped with the *Ford Ambulance Preparation Package*. In addition, Ford urges ambulance manufacturers to follow the recommendation of the *Ford Incomplete Vehicle Manual*, *Ford Truck Body Builder's Layout Book* (and pertinent supplements) and the "Qualified Vehicle Modifiers Guidelines." Using a Ford vehicle without the *Ford Ambulance Preparation Package* to produce an ambulance voids the Ford warranty and could result in elevated underbody temperatures, fuel overpressurization and the risk of fuel expulsion and fires. To determine whether the vehicle is equipped with the *Ford Ambulance Preparation Package*, inspect the information plate on the driver's side door pillar.

Contact the manufacturer of your vehicle to determine whether the ambulance manufacturer's followed Ford's recommendations.



WARNING: Engine exhaust, some of its constituents, and certain vehicle components contain or emit chemicals known to the State of California to cause cancer and birth defects or other reproductive harm. Certain fluids contained in vehicles and certain products of component contain or emit chemicals known to the State of California to cause cancer and birth defects or other reproductive harm.

WARNINGS

Throughout this guide, you will find warnings. Warnings remind you to be especially careful to avoid personal injury.

NEW VEHICLE BREAK-IN

Your vehicle does not need an extensive break-in. Try not to drive continuously at the same speed for the first 1 600 km (1 000 miles) of new vehicle operation. Vary your speed to allow parts to adjust themselves to other parts.

Drive your new vehicle at least 800 km (500 miles) before towing a trailer.

Do not add friction modifier compounds or special break-in oils during the first few thousand kilometers (miles) of operation, since these additives may prevent piston ring seating. See "Engine oil" in the *General Maintenance Information* chapter for more information on oil usage.

Diesel information

DIESEL ENGINE INFORMATION

The diesel engine fuel system consists of:

- a frame-mounted electric fuel supply pump
- an engine mounted fuel filter/water separator
- a fuel restriction sensor
- a unit injector for each cylinder

The combination fuel filter/water separator removes both water and impurities from the fuel. The filter should be changed at the recommended service interval. Refer to the “Service Guide” for more information. The filter bowl should be drained at regular intervals or when the “WATER IN FUEL” light illuminates in the instrument cluster.

The fuel injectors are located in the center of the combustion chambers in the cylinder head between the rocker arm assemblies. The glow plug system and fuel injection system are controlled through the powertrain control module (PCM).

Fuel is drawn from the fuel tank by a frame-mounted electric fuel pump. The fuel pump provides pressurized fuel to the engine and is electronically controlled by the fuel pump PCM relay. The fuel pump contains a pressure relief valve for overpressure protection in the event of restricted flow.

Lubrication system

It is important to change the engine oil at the recommended service intervals, because oil viscosity is important in maintaining the oil pressure required to actuate the fuel injectors. Extended oil change intervals can negatively affect engine performance and fuel economy.

Pressurized oil from the turbocharger is also used to actuate an exhaust backpressure warm-up system (if equipped). Pressurized oil from the turbocharger is routed to the exhaust backpressure actuator. During exhaust backpressure operation, the engine’s sound will be altered and you may notice a change in engine performance while it’s engaged. This function occurs only during cold weather warm-up cycle.

Fast start glow plug system

The glow plug system consists of:

- eight glow plugs
- the glow plug relay
- engine oil temperature (EOT) sensor
- barometric pressure (BARO) sensor

Diesel information

The glow plug system is electronically controlled by the PCM. The PCM energizes the glow plugs immediately after the ignition is placed in the ON position, then determines how long the glow plugs will be on according to the EOT and BARO sensors. The required time for the glow plugs to be energized decreases as the engine oil temperature and barometric pressure increase.

Engine cooling system

The cooling system contains an engine oil cooler which is mounted to the side of the cylinder block. The cooler's function is to regulate engine oil temperature.

Engine governed speed

The engine governor is controlled by the PCM. The PCM controls fuel input to limit maximum engine speed. It will not, however, prevent engine overspeeding resulting from downshifting at high vehicle speed or by descending steep grades at too high a vehicle speed for the selected transmission gear.

For maximum vehicle speed in various gears, refer to the "Transmission shift speed" chart in the *Driving tips* chapter. Do not exceed 3,600 rpm. Maximum engine governed speed is 3,000–4,000 rpm depending on engine load. Excessive rpm can only be achieved by manually downshifting at too high of a vehicle speed.

Operating the engine beyond the governed speed can cause severe engine damage.

Air filter restriction gauge, E-Series

The restriction gauge, located on the clean-air side of the air cleaner upper housing, shows if the air filter is clogged. Refer to "Engine Compartment" in *Service Points* chapter.

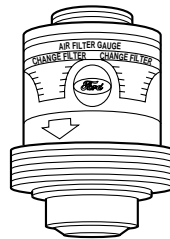

Diesel information

The air filter element should be replaced when the colored band on the gauge reaches the CHANGE FILTER mark. Engine performance and fuel economy are adversely affected when maximum restriction is reached. After servicing the air filter element, reset the restriction gauge by pressing the button the end of the gauge.

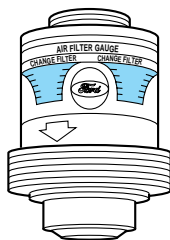

Air filter restriction gauge, F-250/350/450/550 & Excursion

The restriction gauge, located on the upper housing of the air cleaner assembly, monitors the condition of the air filter element in two ways:

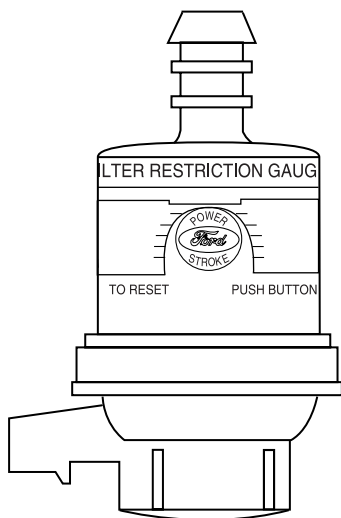

First, the colored indicator inside the gauge highlights the percentage that the air filter element is clogged with dust or contaminants. Refer to “Engine Compartment” in *Service Points* chapter.

Second, the gauge contains an electrical switch which illuminates a warning light on the instrument cluster when the air filter element is 100% clogged. Refer to “F-250/350/450/550, Excursion” in *Warning Lights* chapter.

Diesel information

Check the air filter restriction gauge whenever the hood is raised to perform general engine maintenance. If the vehicle is operated in extremely dusty conditions, check the gauge at least every 805 km (500 miles), or two weeks, whichever comes first.

The air filter element must be replaced when the colored band on the gauge reaches the CHANGE FILTER mark. Engine performance and fuel economy are adversely affected when the maximum restriction is reached.

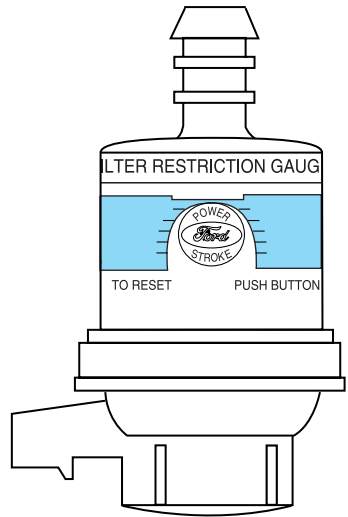

Blowing-out the air filter element with compressed air is not recommended as the compressed air may damage the filter paper.

NOTE: It is not possible to determine the level of filter clogging by visual appearance alone. A filter which appears to be dirty may actually have several thousand kilometers (miles) of life remaining.

Always use the underhood air filter restriction gauge or engine air filter warning light on the instrument cluster to determine when the air filter element needs to be changed.

Diesel information

After servicing the air filter element, reset the restriction gauge by pressing the button on the end of the gauge.

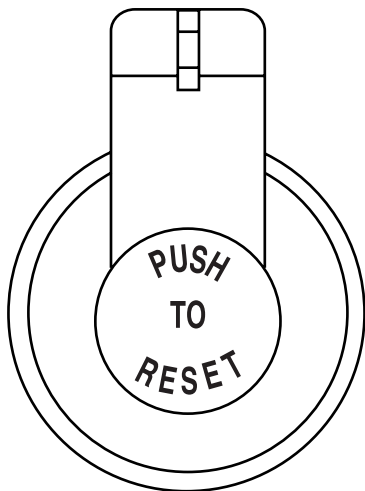

NOTE: If the vehicle is operated in a heavy snow storm, in blowing snow or the vehicle is equipped with a snowplow, the engine air filter element may become partially clogged with snow and/or ice. If this occurs, the air filter restriction gauge will move to the CHANGE FILTER mark and the engine may experience a significant reduction in power output. The vehicle may be driven under these conditions for up to 160 km (100 miles) without damage to the engine or related components.

At the earliest opportunity, clear all snow and ice from the air induction system and replace the air filter element, or remove the element and dry it out. Reset the restriction gauge by pressing the button on the end of the gauge.

The air filter warning light on the instrument cluster may be used, in addition to the underhood restriction gauge, to monitor the condition of the air filter element. Refer to the *Warning Lights* chapter.

Warning lights

E-SERIES

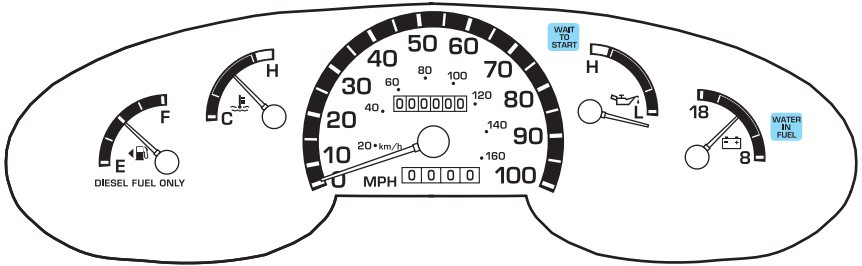

F-250/350/450/550, EXCURSION

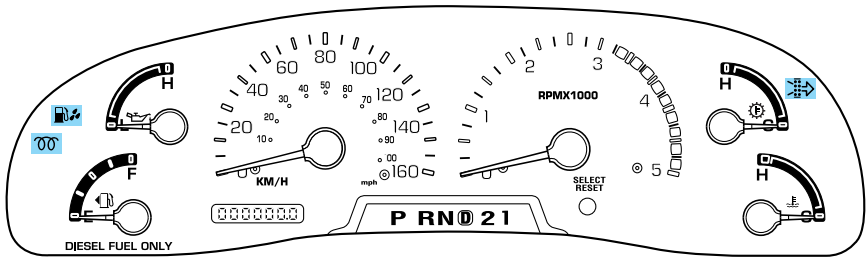

WAIT TO START

- E-Series
- F-250/350/450/550, Excursion

**WAIT
TO
START**



With the key in the ON position, the WAIT TO START light will illuminate if glow plug heat is necessary as a starting aid. Wait until the light goes off before starting. The light should always illuminate briefly, when the ignition key is in the ON position. If the light does not illuminate, there may be a problem. Refer to the *Starting* chapter in this guide. After the engine starts, the light should remain off.

Warning lights

The light should always illuminate at least momentarily when the engine is cold and the ignition is turned to ON. If it does not illuminate, the glow plug system should be checked and repaired promptly to avoid difficulty in cold starting.

WATER IN FUEL

- E-Series
- F-250/350/450/550, Excursion

**WATER
IN
FUEL**



During refueling, it is possible for water-contaminated diesel fuel to be pumped into your tank. Your vehicle fuel system is equipped with a fuel filter/water separator to remove water from the fuel. The WATER IN FUEL light will illuminate when the ignition is turned to START (as part of the light function check) and when the fuel filter/water separator has a significant quantity of water in it.

If the light illuminates when the engine is running, stop the vehicle as soon as safely possible, shut off the engine, then drain the filter bowl. Refer to the *General maintenance* chapter for drain procedure. Allowing water to stay in the system could result in extensive damage to, or failure of, the fuel injection system.



Do not drain the water separator while the engine is running. Fuel may ignite if the separator is drained while the engine is running or the vehicle is moving.

Warning lights

ENGINE AIR FILTER (F-250/350/450/550 & EXCURSION)

The engine air filter warning light illuminates when the air filter restriction gauge reaches the CHANGE FILTER mark.

The vehicle may be driven with the engine air filter warning light illuminated for up to 402 km (250 miles) without damaging the engine or related components. However, the air filter element **must** be replaced at the earliest opportunity. Refer to “Air filter restriction gauge” in the *Diesel information* chapter for more information.

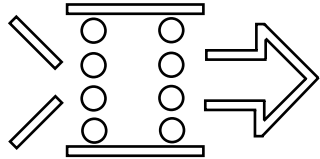

Starting

STARTING THE ENGINE

Read all starting instructions carefully before you start your vehicle.

For temperatures below 0°C (32°F), the use of the correct grade engine oil is essential for proper operation.

If your vehicle is equipped with a manual transmission, make sure the parking brake is set fully before you turn the key. Depress the clutch pedal and place the gearshift in the neutral position. The clutch must be fully depressed in order to operate the starter. Do not press the accelerator during starting.

If your vehicle is equipped with an automatic transmission, ensure the gearshift lever is in P (Park) and the parking brake is set before you turn the key. Do not press the accelerator during starting.

COLD WEATHER STARTING

Do not crank the engine for more than 30 seconds at a time as starter damage may occur. If the engine fails to start, turn the key to OFF and wait 30 seconds before trying again.

Do not use starting fluid such as ether in the air intake system (see Air Cleaner Decal). Such fluid could cause immediate explosive damage to the engine and possible personal injury.

Do not add gasoline, gasohol or alcohol to diesel fuel. This practice creates a serious fire hazard and causes engine performance problems.

1. Make sure all vehicle occupants have buckled their safety belts. For more information on safety belts and their proper usage, refer to *Seating and safety restraints* chapter in the owner guide.

2. Make sure the headlamps and vehicle accessories are off.

3. Turn the key to the ON position.

When the WAIT TO START light goes off, turn the key to START. (For Canadian vehicles, the daytime running lamps will be on if the parking brake is not applied and the key is turned to ON.)

**WAIT
TO
START**

4. When the engine starts, release the key. The glow plugs will continue to be activated for up to two minutes. If the engine is not started before the activation ceases, the glow plug system must be reset by turning the ignition key to OFF.

5. After the engine starts, allow it to idle for about 15 seconds. (Do not increase engine speed until the oil pressure gauge indicates normal pressure.)

STOPPING THE ENGINE

Turn the ignition to OFF. To prolong engine life (after extended high speed or maximum GVW operation), it is recommended that a hot engine be allowed to operate at low idle for about 7–10 minutes which would allow sufficient time for the turbocharged engine to cool down.

COLD WEATHER OPERATION

Changing to a lighter grade engine oil also makes starting easier under these conditions. Refer to “Engine Oil Specifications” in the *General maintenance information* chapter.

At temperatures below -7°C (20°F), Number 2–D diesel fuel may thicken enough to clog the fuel filter. Your engine is equipped with a fuel filter/heater/water/separator to keep the wax melted which will help prevent fuel filter clogging. However, if the engine starts but stalls after a short time and will not restart, the fuel filter may be clogged. For best results in cold weather, use Number 1–D diesel fuel or “winterized” Number 2–D diesel fuel which has an additive to minimize wax formation.

Your vehicle is also equipped with a bypass relief valve, located on the in-tank fuel sending unit, which provides fuel flow to the engine if the fuel pickup should become plugged by ice or wax. To allow this bypass valve to function and avoid engine fuel starvation, it is recommended that, during cold weather operation 0°C (32°F) or below, the fuel level in your tank should not be allowed to drop below 1/4 full. This will help prevent air from entering the fuel system and stalling the engine.

In cold weather below 0°C (32°F) your diesel engine will slowly increase to a higher idle speed if left idling in P (Park). The sound of the engine may change also, as an exhaust device engages to improve heater performance and reduce exhaust smoke.

Operation in snow

Vehicle operation in heavy snowfall or in dry loose snow that may swirl around the front of the vehicle may feed excessive amounts of snow into the air intake system. This could plug the air cleaner with snow and cause the engine to stall.

Refer to “Air filter restriction gauge” in the *Diesel information* chapter and Engine air filter in the *Warning lights* chapter for more information.

Starting

Operation in standing water

Ingestion of water into the diesel engine can result in immediate and severe damage to the engine. If driving through water, slow down to avoid splashing water into the intake. If the engine stalls, and ingestion of water into the engine is suspected, do not try to restart the engine. Consult your dealer for service immediately. Follow the cylinder compression test procedure outlined in the Workshop Manual, then check the engine oil for contamination.

Engine block heater (if equipped)

Refer to the *Starting* chapter in your Owner Guide.

DUAL FUEL TANK SELECTOR CONTROL (IF EQUIPPED)

If your vehicle is equipped with dual fuel tanks, you will have a selector control, located to the right of the steering wheel, which allows you to draw fuel from either tank. Your fuel gauge will display the amount of fuel in the currently selected tank.

Fuel level indication is delayed for several minutes when the tank selector switch is actuated. Fuel level indication can be obtained immediately by turning off and restarting the engine.

MANUAL TRANSMISSION SHIFT SPEEDS

Do not overspeed the engine when going downhill or steep grades. If equipped, use the tachometer and do not allow engine speed to exceed the redline area. Operating the engine beyond the recommended speeds can cause severe engine damage.

If your vehicle is an F-Series equipped with a manual transmission, your vehicle has an electronic operating strategy which protects the engine system when the engine is operating with high coolant temperatures; fueling to the engine will be modified to prevent damage to the engine. Some power loss may be experienced if the vehicle is overloaded.

Upshift and downshift according to the following shift speed charts:

Upshifts when accelerating (recommended for best fuel economy)		
6-speed transmission		
Shift from:	Transfer case position ¹ (if equipped)	
	2H or 4H	4L
LO-1	8 km/h (5 mph)	3 km/h (2 mph)
1-2	16 km/h (10 mph)	6 km/h (4 mph)
2-3	32 km/h (20 mph)	13 km/h (8 mph)
3-4	48 km/h (30 mph)	19 km/h (12 mph)
4	64 km/h (40 mph)	24 km/h (15 mph)
-  (Overdrive)		

Driving tips

Maximum downshift speeds¹		
6-speed transmission		
Shift from:	Transfer case position (if equipped) ²	
	2H or 4H	4L
Ⓣ (Overdrive) - 4	72 km/h (45 mph)	26 km/h (16 mph)
4-3	56 km/h (35 mph)	19 km/h (12 mph)
3-2	32 km/h (20 mph)	13 km/h (8 mph)
2-1	8 km/h (5 mph)	3 km/h (2 mph)
1-LO	Only shift to LO when at a stop.	
¹ Use 2H or 4H for 4WD equipped vehicles.		
² Downshift at lower speeds when driving on slippery surfaces.		

TRAILER TOWING

Refer to your “Owner Guide” for full details on towing a trailer.

E-Series trailer towing tables

Your vehicle may tow a class I, II or III trailer provided the maximum trailer weight is less than or equal to the maximum trailer weight listed for your engine and rear axle ratio on the following charts.

GCWR (Gross Combined Weight Rating)/Trailer Weights			
Rear axle ratio	Maximum GCWR-kg (lbs.)	Trailer weight range-kg (lbs.) (0-Maximum)	Maximum Frontal Area Of Trailer-m² (ft²)
Regular Van E-350			
3.55	7 258 (16 000)	4 536 (10 000)	5.52 (60)
4.10	9 072 (20 000)	4 536 (10 000)	5.52 (60)
Super Van E-350			
3.55	7 258 (16 000)	4 445 (9 800)	5.52 (60)
4.10	9 072 (20 000)	4 536 (10 000)	5.52 (60)
Regular E-350 12 passenger Wagon			
3.55	7 258 (16 000)	4 309 (9 500)	5.52 (60)
4.10	9 072 (20 000)	4 536 (10 000)	5.52 (60)

Driving tips

GCWR (Gross Combined Weight Rating)/Trailer Weights			
Rear axle ratio	Maximum GCWR-kg (lbs.)	Trailer weight range-kg (lbs.) (0-Maximum)	Maximum Frontal Area Of Trailer-m² (ft²)
Super E-350 15 passenger Wagon			
3.55	7 258 (16 000)	4 173 (9 200)	5.52 (60)
4.10	9 072 (20 000)	4 536 (10 000)	5.52 (60)
E-350 RV Cutaway (single rear wheel)			
4.10	9 072 (20 000)	4 717 (10 400)	5.52 (60)
E-350 RV Cutaway (dual rear wheel)			
4.10	9 072 (20 000)	4 309 (9 500)	5.52 (60)
E-350 Commercial Cutaway (single rear wheel)			
4.10	9 072 (20 000)	4 717 (10 400)	5.52 (60)
E-350 Commercial Cutaway (dual rear wheel)			
4.10	9 072 (20 000)	4 400 (9 700)	5.52 (60)
E-450			
4.10	9 072 (20 000)	4 536 (10 000)	5.52 (60)
For high altitude operation reduce GCWR by 2% per 300 meters (1 000 ft) elevation.			
To determine the maximum trailer weight designed for you particular vehicle as equipped, follow the section <i>Calculating the load your vehicle can tow/carry</i> earlier in this chapter.			

Your vehicle's load capacity is designated by weight, not by volume, so you cannot necessarily use all available space when loading a vehicle.

Distribute the load so that only 10 to 15% of the total is on the tongue. Tie down the load so that it does not shift and change the weight on the hitch.

Towing a trailer places an additional load on your vehicle's engine, transmission, axle, brakes, tires and suspension. Inspect these components carefully after any towing operation.



Do not exceed the GVWR or the GAWR specified on the certification label.

Driving tips



Towing trailers beyond the maximum recommended gross trailer weight could result in engine damage, transmission/axle damage, structural damage, loss of control, and personal injury.

Trailer towing tables

Excursion			
Model	Rear axle ratio	Maximum GCWR - kg (lbs.)	Maximum trailer weight - kg (lbs.)
4x2	3.73	9 072 (20 000)	4 763 (10 500)
4x4	3.73	9 072 (20 000)	4 990 (11 000)

F-250/350/450/550 Pick-up w/out fifth wheel			
Engine	Rear axle ratio	Maximum GCWR - kg (lbs.)	Maximum trailer weight - kg (lbs.)
7.3L	All	9 072 (20 000)	5 670 (12 500)

F-250/350 Regular Cab Single Rear Wheel 4x2 w/manual transmission and fifth wheel			
Engine	Rear axle ratio	Maximum GCWR - kg (lbs.)	Maximum trailer weight - kg (lbs.)
7.3L	All	9 072 (20 000)	6 260 (13 800)

F-250/350 Regular Cab Single Rear Wheel 4x2 w/automatic transmission and fifth wheel			
Engine	Rear axle ratio	Maximum GCWR - kg (lbs.)	Maximum trailer weight - kg (lbs.)
7.3L	All	9 072 (20 000)	6 305 (13 900)

Driving tips

F-250/350 Regular Cab Single Rear Wheel 4x4 w/manual transmission and fifth wheel

Engine	Rear axle ratio	Maximum GCWR - kg (lbs.)	Maximum trailer weight - kg (lbs.)
7.3L	All	9 072 (20 000)	6 033 (13 300)

F-250/350 Regular Cab Single Rear Wheel 4x4 w/automatic transmission and fifth wheel

Engine	Rear axle ratio	Maximum GCWR - kg (lbs.)	Maximum trailer weight - kg (lbs.)
7.3L	All	9 072 (20 000)	6 078 (13 400)

F-350 Regular Cab Dual Rear Wheel 4x2 w/fifth wheel

Engine	Rear axle ratio	Maximum GCWR - kg (lbs.)	Maximum trailer weight - kg (lbs.)
7.3L	All	9 072 (20 000)	6 078 (13 400)

F-350 Regular Cab Dual Rear Wheel 4x4 w/fifth wheel

Engine	Rear axle ratio	Maximum GCWR - kg (lbs.)	Maximum trailer weight - kg (lbs.)
7.3L	All	9 072 (20 000)	5 897 (13 000)

F-250/350 SuperCab Single Rear Wheel 4x2 w/manual transmission and fifth wheel

Engine	Rear axle ratio	Maximum GCWR - kg (lbs.)	Maximum trailer weight - kg (lbs.)
7.3L	All	9 072 (20 000)	6 169 (13 600)

Driving tips

F-250/350 SuperCab Single Rear Wheel 4x2 w/automatic transmission and fifth wheel

Engine	Rear axle ratio	Maximum GCWR - kg (lbs.)	Maximum trailer weight - kg (lbs.)
7.3L	All	9 072 (20 000)	6 214 (13 700)

F-250/350 SuperCab Single Rear Wheel 4x4 w/manual transmission and fifth wheel

Engine	Rear axle ratio	Maximum GCWR - kg (lbs.)	Maximum trailer weight - kg (lbs.)
7.3L	All	9 072 (20 000)	5 987 (13 200)

F-250/350 SuperCab Single Rear Wheel 4x4 w/automatic transmission and fifth wheel

Engine	Rear axle ratio	Maximum GCWR - kg (lbs.)	Maximum trailer weight - kg (lbs.)
7.3L	All	9 072 (20 000)	6 033 (13 300)

F-350 SuperCab Dual Rear Wheel 4x2 w/fifth wheel

Engine	Rear axle ratio	Maximum GCWR - kg (lbs.)	Maximum trailer weight - kg (lbs.)
7.3L	All	9 072 (20 000)	5 942 (13 100)

F-350 SuperCab Dual Rear Wheel 4x4 w/manual transmission and fifth wheel

Engine	Rear axle ratio	Maximum GCWR - kg (lbs.)	Maximum trailer weight - kg (lbs.)
7.3L	All	9 072 (20 000)	5 761 (12 700)

Driving tips

F-350 SuperCab Dual Rear Wheel 4x4 w/automatic transmission and fifth wheel

Engine	Rear axle ratio	Maximum GCWR - kg (lbs.)	Maximum trailer weight - kg (lbs.)
7.3L	All	9 072 (20 000)	5 806 (12 800)

F-250/350 Crew Cab Single Rear Wheel 4x2 w/manual transmission and fifth wheel

Engine	Rear axle ratio	Maximum GCWR - kg (lbs.)	Maximum trailer weight - kg (lbs.)
7.3L	All	9 072 (20 000)	6 033 (13 300)

F-250/350 Crew Cab Single Rear Wheel 4x2 w/automatic transmission and fifth wheel

Engine	Rear axle ratio	Maximum GCWR - kg (lbs.)	Maximum trailer weight - kg (lbs.)
7.3L	All	9 072 (20 000)	6 078 (13 400)

F-250/350 Crew Cab Single Rear Wheel 4x4 w/manual transmission and fifth wheel

Engine	Rear axle ratio	Maximum GCWR - kg (lbs.)	Maximum trailer weight - kg (lbs.)
7.3L	All	9 072 (20 000)	5 851 (12 900)

F-250/350 Crew Cab Single Rear Wheel 4x4 w/automatic transmission and fifth wheel

Engine	Rear axle ratio	Maximum GCWR - kg (lbs.)	Maximum trailer weight - kg (lbs.)
7.3L	All	9 072 (20 000)	5 897 (13 000)

Driving tips

F-350 Crew Cab Dual Rear Wheel 4x2 w/manual transmission and fifth wheel			
Engine	Rear axle ratio	Maximum GCWR - kg (lbs.)	Maximum trailer weight - kg (lbs.)
7.3L	All	9 072 (20 000)	5 897 (13 000)

F-350 Crew Cab Dual Rear Wheel 4x2 w/automatic transmission and fifth wheel			
Engine	Rear axle ratio	Maximum GCWR - kg (lbs.)	Maximum trailer weight - kg (lbs.)
7.3L	All	9 072 (20 000)	5 942 (13 100)

F-350 Crew Cab Dual Rear Wheel 4x4 w/manual transmission and fifth wheel			
Engine	Rear axle ratio	Maximum GCWR - kg (lbs.)	Maximum trailer weight - kg (lbs.)
7.3L	All	9 072 (20 000)	5 761 (12 700)

F-350 Crew Cab Dual Rear Wheel 4x4 w/automatic transmission and fifth wheel			
Engine	Rear axle ratio	Maximum GCWR - kg (lbs.)	Maximum trailer weight - kg (lbs.)
7.3L	All	9 072 (20 000)	5 806 (12 800)

F-350 Regular Chassis Cab Single Rear Wheel 4x2 w/manual transmission (fifth wheel towing)			
Engine	Rear axle ratio	Maximum GCWR - kg (lbs.)	Maximum trailer weight - kg (lbs.)
7.3L	All	9 072 (20 000)	5 942 (13 100)

Driving tips

F-350 Regular Chassis Cab Single Rear Wheel 4x2 w/automatic transmission (fifth wheel towing)			
Engine	Rear axle ratio	Maximum GCWR - kg (lbs.)	Maximum trailer weight - kg (lbs.)
7.3L	All	9 072 (20 000)	5 987 (13 200)

F-350 Regular Chassis Cab Single Rear Wheel 4x4 (fifth wheel towing)			
Engine	Rear axle ratio	Maximum GCWR - kg (lbs.)	Maximum trailer weight - kg (lbs.)
7.3L	All	9 072 (20 000)	5 761 (12 700)

F-350 Regular Chassis Cab Dual Rear Wheel 4x2 (fifth wheel towing)			
Engine	Rear axle ratio	Maximum GCWR - kg (lbs.)	Maximum trailer weight - kg (lbs.)
7.3L	All	9 072 (20 000)	5 806 (12 800)

F-350 Regular Chassis Cab Dual Rear Wheel 4x4 (fifth wheel towing)			
Engine	Rear axle ratio	Maximum GCWR - kg (lbs.)	Maximum trailer weight - kg (lbs.)
7.3L	All	9 072 (20 000)	5 579 (12 300)

F-450 Regular Chassis Cab Dual Rear Wheel 4x2 (fifth wheel towing)			
Engine	Rear axle ratio	Maximum GCWR - kg (lbs.)	Maximum trailer weight - kg (lbs.)
7.3L	All	11 793 (26 000)	8 210 (18 100)

Driving tips

F-450 Regular Chassis Cab Dual Rear Wheel 4x4 (fifth wheel towing)			
Engine	Rear axle ratio	Maximum GCWR - kg (lbs.)	Maximum trailer weight - kg (lbs.)
7.3L	All	11 793 (26 000)	8 074 (17 800)

F-550 Regular Chassis Cab Dual Rear Wheel 4x2 (fifth wheel towing)			
Engine	Rear axle ratio	Maximum GCWR - kg (lbs.)	Maximum trailer weight - kg (lbs.)
7.3L	All	11 793 (26 000)	8 165 (18 000)

F-550 Regular Chassis Cab Dual Rear Wheel 4x4 (fifth wheel towing)			
Engine	Rear axle ratio	Maximum GCWR - kg (lbs.)	Maximum trailer weight - kg (lbs.)
7.3L	All	11 793 (26 000)	8 029 (17 700)

F-350 Super Chassis Cab Single Rear Wheel 4x2 (fifth wheel towing)			
Engine	Rear axle ratio	Maximum GCWR - kg (lbs.)	Maximum trailer weight - kg (lbs.)
7.3L	All	9 072 (20 000)	5 806 (12 800)

F-350 Super Chassis Cab Single Rear Wheel 4x4 w/manual transmission (fifth wheel towing)			
Engine	Rear axle ratio	Maximum GCWR - kg (lbs.)	Maximum trailer weight - kg (lbs.)
7.3L	All	9 072 (20 000)	5 579 (12 300)

Driving tips

F-350 Super Chassis Cab Single Rear Wheel 4x4 w/automatic transmission (fifth wheel towing)			
Engine	Rear axle ratio	Maximum GCWR - kg (lbs.)	Maximum trailer weight - kg (lbs.)
7.3L	All	9 072 (20 000)	5 625 (12 400)

F-350 Super Chassis Cab Dual Rear Wheel 4x2 (fifth wheel towing)			
Engine	Rear axle ratio	Maximum GCWR - kg (lbs.)	Maximum trailer weight - kg (lbs.)
7.3L	All	9 072 (20 000)	5 625 (12 400)

F-350 Super Chassis Cab Dual Rear Wheel 4x4 (fifth wheel towing)			
Engine	Rear axle ratio	Maximum GCWR - kg (lbs.)	Maximum trailer weight - kg (lbs.)
7.3L	All	9 072 (20 000)	5 443 (12 000)

F-450 Super Chassis Cab Dual Rear Wheel 4x2 w/manual transmission (fifth wheel towing)			
Engine	Rear axle ratio	Maximum GCWR - kg (lbs.)	Maximum trailer weight - kg (lbs.)
7.3L	All	11 793 (26 000)	8 029 (17 700)

F-450 Super Chassis Cab Dual Rear Wheel 4x2 w/automatic transmission (fifth wheel towing)			
Engine	Rear axle ratio	Maximum GCWR - kg (lbs.)	Maximum trailer weight - kg (lbs.)
7.3L	All	11 793 (26 000)	8 074 (17 800)

Driving tips

F-450 Super Chassis Cab Dual Rear Wheel 4x4 w/manual transmission (fifth wheel towing)

Engine	Rear axle ratio	Maximum GCWR - kg (lbs.)	Maximum trailer weight - kg (lbs.)
7.3L	All	11 793 (26 000)	7 847 (17 300)

F-450 Super Chassis Cab Dual Rear Wheel 4x4 w/automatic transmission (fifth wheel towing)

Engine	Rear axle ratio	Maximum GCWR - kg (lbs.)	Maximum trailer weight - kg (lbs.)
7.3L	All	11 793 (26 000)	7 893 (17 400)

F-550 Super Chassis Cab Dual Rear Wheel 4x2 w/manual transmission (fifth wheel towing)

Engine	Rear axle ratio	Maximum GCWR - kg (lbs.)	Maximum trailer weight - kg (lbs.)
7.3L	All	11 793 (26 000)	7 756 (17 100)

F-550 Super Chassis Cab Dual Rear Wheel 4x2 w/automatic transmission (fifth wheel towing)

Engine	Rear axle ratio	Maximum GCWR - kg (lbs.)	Maximum trailer weight - kg (lbs.)
7.3L	All	11 793 (26 000)	8 029 (17 700)

F-550 Super Chassis Cab Dual Rear Wheel 4x4 w/manual transmission (fifth wheel towing)

Engine	Rear axle ratio	Maximum GCWR - kg (lbs.)	Maximum trailer weight - kg (lbs.)
7.3L	All	11 793 (26 000)	7 802 (17 200)

Driving tips

F-550 Super Chassis Cab Dual Rear Wheel 4x4 w/automatic transmission (fifth wheel towing)

Engine	Rear axle ratio	Maximum GCWR - kg (lbs.)	Maximum trailer weight - kg (lbs.)
7.3L	All	11 793 (26 000)	7 847 (17 300)

F-350 Crew Chassis Cab Single Rear Wheel 4x2 (fifth wheel towing)

Engine	Rear axle ratio	Maximum GCWR - kg (lbs.)	Maximum trailer weight - kg (lbs.)
7.3L	All	9 072 (20 000)	5 715 (12 600)

F-350 Crew Chassis Cab Single Rear Wheel 4x4 w/manual transmission (fifth wheel towing)

Engine	Rear axle ratio	Maximum GCWR - kg (lbs.)	Maximum trailer weight - kg (lbs.)
7.3L	All	9 072 (20 000)	5 488 (12 100)

F-350 Crew Chassis Cab Single Rear Wheel 4x4 w/automatic transmission (fifth wheel towing)

Engine	Rear axle ratio	Maximum GCWR - kg (lbs.)	Maximum trailer weight - kg (lbs.)
7.3L	All	9 072 (20 000)	5 534 (12 200)

F-350 Crew Chassis Cab Dual Rear Wheel 4x2 w/manual transmission (fifth wheel towing)

Engine	Rear axle ratio	Maximum GCWR - kg (lbs.)	Maximum trailer weight - kg (lbs.)
7.3L	All	9 072 (20 000)	5 534 (12 200)

Driving tips

F-350 Crew Chassis Cab Dual Rear Wheel 4x2 w/automatic transmission (fifth wheel towing)			
Engine	Rear axle ratio	Maximum GCWR - kg (lbs.)	Maximum trailer weight - kg (lbs.)
7.3L	All	9 072 (20 000)	5 579 (12 300)

F-350 Crew Chassis Cab Dual Rear Wheel 4x4 (fifth wheel towing)			
Engine	Rear axle ratio	Maximum GCWR - kg (lbs.)	Maximum trailer weight - kg (lbs.)
7.3L	All	9 072 (20 000)	5 352 (11 800)

F-450 Crew Chassis Cab Dual Rear Wheel 4x2 (fifth wheel towing)			
Engine	Rear axle ratio	Maximum GCWR - kg (lbs.)	Maximum trailer weight - kg (lbs.)
7.3L	All	11 793 (26 000)	7 938 (17 500)

F-450 Crew Chassis Cab Dual Rear Wheel 4x4 (fifth wheel towing)			
Engine	Rear axle ratio	Maximum GCWR - kg (lbs.)	Maximum trailer weight - kg (lbs.)
7.3L	All	11 793 (26 000)	7 802 (17 200)

F-550 Crew Chassis Cab Dual Rear Wheel 4x2 w/manual transmission (fifth wheel towing)			
Engine	Rear axle ratio	Maximum GCWR - kg (lbs.)	Maximum trailer weight - kg (lbs.)
7.3L	All	11 793 (26 000)	7 893 (17 400)

F-550 Crew Chassis Cab Dual Rear Wheel 4x2 w/automatic transmission (fifth wheel towing)

Engine	Rear axle ratio	Maximum GCWR - kg (lbs.)	Maximum trailer weight - kg (lbs.)
7.3L	All	11 793 (26 000)	7 938 (17 500)
7.3L	All	13 608 (30 000)	9 752 (21 500)

F-550 Crew Chassis Cab Dual Rear Wheel 4x4 (fifth wheel towing)

Engine	Rear axle ratio	Maximum GCWR - kg (lbs.)	Maximum trailer weight - kg (lbs.)
7.3L	All	11 793 (26 000)	7 756 (17 100)

General maintenance information

SCHEDULED MAINTENANCE

The Scheduled Maintenance Services in the Service Guide are required because they are considered essential to the life and performance of your vehicle.

Use only recommended fuel, lubricants, fluids and service parts conforming to Ford specifications. Motorcraft parts are designed and built for best performance in your vehicle.

CLEANING THE ENGINE

Engines are more efficient when they are clean because grease and dirt buildup keep the engine warmer than normal. When washing:

- The engine must be cool to the touch before spraying with water.
- **Never spray a hot engine with cold water, as damage to the engine block or engine components may occur.**
- Use caution when using a self-serve power washer (1000psi maximum pressure) to clean the engine, as the high-pressure fluid could penetrate the sealed parts and cause damage.
- **Never apply anything to any exposed belts in the engine compartment, including the belt dressing.**

For general cleaning of the engine compartment, wet the cool engine with water, spray Triple Clean (EOAZ-19526-AA) on all parts that require cleaning and pressure rinse the area with cool water.

General maintenance information

Cover the highlighted areas to prevent water damage when cleaning the engine (**never wash or rinse the engine while it is running; water in the running engine may cause internal damage**):

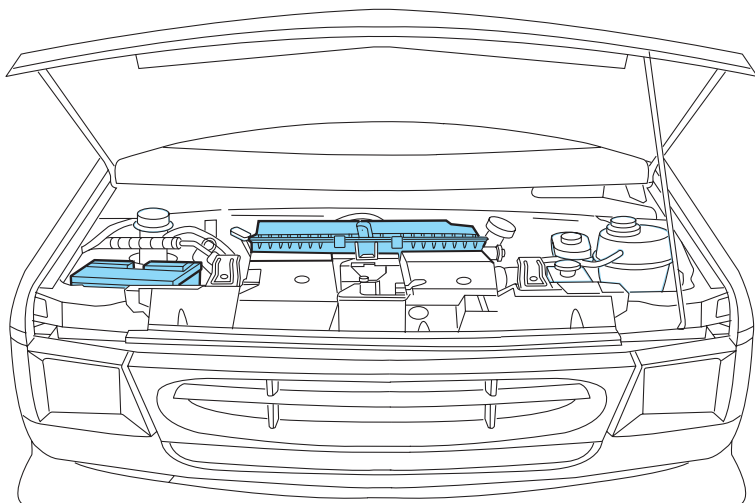

- E-Series

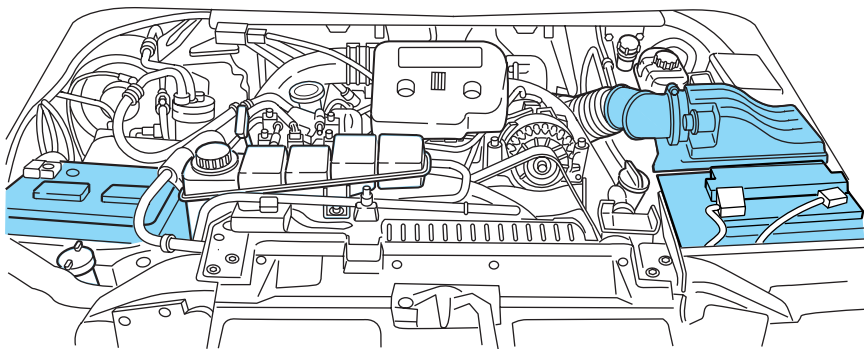

- F-250/350/450/550 & Excursion

General maintenance information

FUEL REQUIREMENTS

The engine is designed to use low sulfur number 1-D or 2-D diesel fuel only. At temperatures below -7°C (20°F), number 1-D or winter blend number 2-D fuel is recommended. (See “Cold Weather Operation” in the *Starting* chapter.)

Do not use fuel intended for agricultural use (agricultural fuel is dyed red), home heating oil or any diesel fuel not intended for highway use. Damage to the fuel injection system or engine can occur if an improper fuel is used.

Do not add gasoline, gasohol or alcohol to diesel fuel. This practice creates a serious fire hazard and engine performance problems.

It should not be necessary to add any aftermarket additives to your fuel tank if you use a properly formulated diesel fuel that meets the ASTM D 975 industry specification. Aftermarket additives can damage the injector system or engine.

Do not blend used engine oil with diesel fuel under any circumstances. Blending used oil with the fuel will significantly increase your vehicle's exhaust emissions and reduce engine life due to increased internal wear.



Do not crank the engine for more than 30 seconds at a time as damage to the starter motor may result.

If the engine fails to start in 30 seconds, turn the key to the OFF position and wait 30 seconds before trying again.

Truck stops have pumps and nozzles designed for larger, heavy-duty trucks. When refueling at truck stops: if the nozzle shuts off repeatedly when refueling, wait 5–10 seconds; then use a slower rate of flow (don't depress the nozzle trigger as far).

If air is allowed to enter the fuel system (during fuel filter change or if you run out of fuel) the engine will purge the trapped air as it runs. The engine may run rough and produce white smoke while air is in the system. This is normal and should correct itself in a short time.

An engine that suddenly becomes noisy or operates poorly after a fuel fill could be using substandard fuel (i.e., high water content, low cetane rating or gasoline in the fuel). Diesel fuel should be purchased from a reputable station which sells a large amount of diesel fuel.

Care should be taken whenever diesel fuel is stored. Use only clean, approved containers which will prevent the entry of dirt or water.

General maintenance information

Diesel fuel must not be stored in a galvanized container. The fuel will dissolve the zinc in a galvanized container. The zinc will then remain in solution until it is run through the engine where it will be deposited in the fuel injectors causing expensive-to-repair damage.

CHANGING FUEL FILTER

Removal — F-250/350/450/550 and Excursion

1. Remove the engine appearance cover.
2. Remove the fuel filter cap by turning counterclockwise.
3. Remove and discard old fuel filter element and fuel filter o-ring.
4. Carefully clean the mating surfaces.

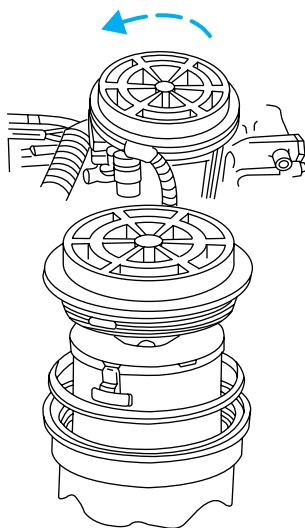

Removal — E-Series

1. Remove the engine appearance cover.
2. Disconnect the battery ground cable, then all electrical connectors, vacuum tubes and fasteners as necessary for removal.
3. Release the four retaining clamps on the air cleaner assembly, then lift the air cleaner cover and remove the air cleaner(s).
4. Loosen the clamp on the air inlet tube, then disconnect the air inlet tube from the resonator.
5. Remove the three bolts on the turbocharger heat shield, then the turbocharger heat shield.
6. Remove the bolt and resonator from the vehicle.

General maintenance information

7. Remove the fuel filter cap by turning counterclockwise.
8. Remove and discard old fuel filter element and fuel filter o-ring.
9. Carefully clean the mating surfaces.

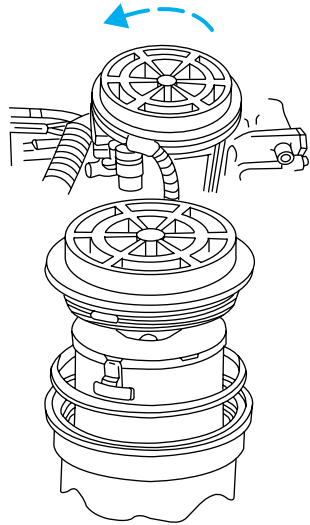

Installation — F-250/350/450/550 and Excursion

The engine will not run properly if the fuel filter is not installed in housing.

1. Apply a coating of clean diesel fuel to the new fuel filter o-ring.
2. Install new fuel filter o-ring onto fuel filter element.
3. Install new fuel filter and o-ring into the fuel filter housing.
4. Tighten cap onto fuel filter housing slowly, allowing fuel to soak into the fuel filter element. Tighten cap until it contacts the housing.
5. Install engine appearance cover.

After replacing the fuel filter, the engine will purge the trapped air as it runs. The engine may run roughly and smoke until the air is completely eliminated.

Using a fuel which has more than average impurities may require the fuel filter to be replaced more frequently than the service interval specifies.

General maintenance information

Installation — E-Series

The engine will not run properly if the fuel filter is not installed in housing.

1. Apply a coating of clean diesel fuel to the new fuel filter o-ring.
2. Install new fuel filter o-ring onto fuel filter element.
3. Install new fuel filter and o-ring into the fuel filter housing.
4. Tighten cap onto fuel filter housing slowly, allowing fuel to soak into the fuel filter element. Tighten cap until it contacts the housing.
5. Install the resonator and resonator bolt.
6. Install the turbocharger heat shield, then the three bolts on the turbocharger heat shield.
7. Connect the air inlet tube to the resonator, then tighten the clamp on the air inlet tube.
8. Install the air cleaner(s), close the air cleaner cover, then close the four retaining clamps on the air cleaner assembly.
9. Connect the battery ground cable, then all electrical connectors, vacuum tubes and fasteners as necessary for installation.
10. Install the engine appearance cover.

After replacing the fuel filter, the engine will purge the trapped air as it runs. The engine may run roughly and smoke until the air is completely eliminated.

Using a fuel which has more than average impurities may require the fuel filter to be replaced more frequently than the service interval specifies.

ENGINE OIL

Checking engine oil level

Because it is normal to add some oil between oil changes, check your engine oil level each time you stop for fuel. To check the engine oil level consistently and accurately, the following procedure is recommended:

1. Have engine at normal operating temperature (at least into the NORMAL range on the engine coolant temperature gauge).
2. Park the vehicle on a level surface, then turn off the engine and open the hood.
3. Allow at least **20 minutes** after engine shutdown to assure that the oil contained in the upper parts of the engine has returned to the oil pan.

General maintenance information

4. Protecting yourself from engine heat, pull out the dipstick, wipe it clean and reinsert fully.

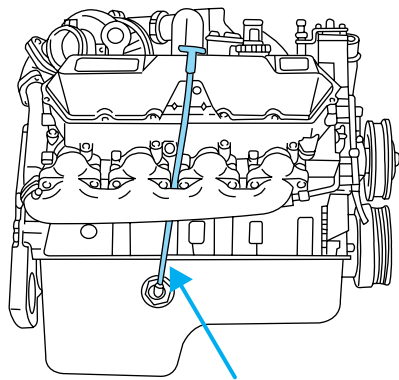

5. Read oil level on both sides of dipstick and use highest level (reading) for the actual engine oil level.

6. Maintain the oil level between ADD and OPERATING RANGE on the dipstick by adding oil as required. The distance from ADD to OPERATING RANGE on the dipstick represents 1.9L (2 quarts). Do not overfill. If the oil level exceeds OPERATING RANGE, oil consumption may result.

Engine oil specifications

To help achieve proper engine performance and durability, it is important that only engine lubricating oils of the proper quality are used in your diesel engine and that the engine oil is changed **no later** than the recommended interval. Diesel engines require specially formulated oil to resist contamination. Proper quality oils also provide maximum efficiency of the crankcase ventilating system which reduces air pollution.

For normal or severe service, use Motorcraft oil or an equivalent oil conforming to Ford Specification WSS-M2C171-C or API Service categories CH-4, CH-4/SJ or CH-4/SL. If CH-4 oil is not available, CG-4 is acceptable..

Engine oils with improved fuel economy properties (energy conserving) are currently available. If you use an energy conserving oil, be sure it meets the recommended Ford Specification, *API* service categories and SAE viscosity grades listed in the Lubricant and Maintenance Materials Specifications chart. Some energy conserving oils *do not* meet the requirements necessary for your diesel engine.

General maintenance information

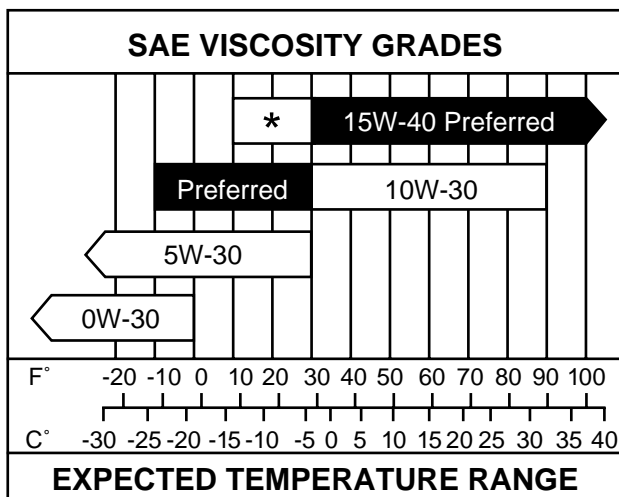

The use of correct oil viscosities for diesel engines is important for satisfactory operation. Determine which oil viscosity best suits the temperature range you expect to encounter for the next service interval.

A symbol has been developed by the American Petroleum Institute (API) to help you select the proper engine oil. It will be included on the oil container you purchase. The top section of the symbol shows the oil performance by the API designation.

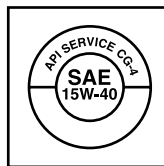

This should match the owner guide recommendation. The center section will show the SAE viscosity grade. The lower section will state energy conserving if the oil has proven fuel saving capabilities.

Changing engine oil and filter

Change your oil and filter according to the "Service Guide". Change more frequently if your vehicle operation includes extended periods of idling or low-speed operation, driving for a long time in cold temperatures or driving short distances. See the following section "Engine Lubrication for Severe Service Operation" for all severe duty restrictions.

Use Ford Engine Oil Filter Part No. F4TZ-6731-A (FL-1995) or equivalent. These filters protect your engine by filtering harmful,

General maintenance information

abrasive or sludge particles. The FL-1995 filters particles significantly smaller than most available “will fit” filters.

To replace, use an oil filter wrench to unscrew the filter from the oil cooler fitting. Turn it horizontally to let excess oil drain off, and remove.



Do not handle a hot oil filter with bare hands.

Clean the filter mounting area on the oil cooler, lightly coat the gasket surface of the new filter with clean engine oil and hand tighten until the gasket contacts the base. **Then tighten another 1-1/4 to 2 turns.** Fill the crankcase and run the engine to check for leaks.



Continuous contact with USED motor oil has caused cancer in laboratory mice. Protect your skin by washing with soap and water.

Engine lubrication for severe service operation

The following severe service operating conditions require unique engine maintenance procedures:

- towing a trailer over 1 600 km (1 000 miles)
- sustained, high speed driving at Gross Vehicle Weight Rating (maximum loaded weight for vehicle operation during hot weather-above 32°C [90°F]).
- frequent or extended idling (over 10 minutes per hour of normal driving).
- operating in severe dust conditions.
- frequent, short trips of 16 km (10 miles) or less during freezing weather

If you are operating your vehicle under any of these conditions, observe the following service procedures:

- Change engine oil and filter every 5 000 km (3 000 miles).
- Use Motorcraft oil or an equivalent oil conforming to Ford Specification WSS-M2C171-C or API categories CH-4, CH-4/SJ or CH-4/SL. If CH-4 oil is not available, CG-4 is acceptable..

For more information refer the *Severe Duty Maintenance Schedule* in the “Service Guide”.

REPLACING THE AIR FILTER ELEMENT

When replacing the air filter element, use the Motorcraft air filter element listed. Refer to *Lubricant and Maintenance Materials Specifications* in this supplement.

General maintenance information

Failure to use the correct air filter element may result in severe engine damage.

1. Remove air filter element from the housing, taking care to prevent dirt from falling into the engine air intake.
2. Clean the air filter housing and cover to ensure good sealing.
3. Install a new air filter element. Be careful not to crimp the filter edges between the air filter housing and cover. This could cause damage to the air filter element and possible severe damage to the engine.

When servicing the air filter, always be sure that the rubber water drain hose is not kinked or obstructed. Failure to do so may result in severe engine damage when driving through deep water and/or encountering unusually heavy precipitation conditions.

FUEL FILTER/WATER SEPARATOR

The engine is equipped with a combination fuel filter/water separator located in the “V” of the engine.

- E-Series

**WATER
IN
FUEL**

- F-250/350/450/550, Excursion

Water should be drained from the filter bowl whenever the warning light comes on or every 8 000 km (5 000 miles). The WATER IN FUEL light will come on when approximately 100 cc (0.2 pints) of water accumulates in the separator.



Replace the fuel filter with Motorcraft Part No. FD-4596 (Ford Part No. F81Z-9N184-AA).

Fuel filter/water separator drain procedure

1. Stop the vehicle and **shut off** the engine.



The vehicle must be stopped with the engine off when draining the fuel filter/water separator. Fuel may ignite if separator is drained while the engine is running or vehicle is moving.

General maintenance information

2. Open the hood. Place an appropriate container under the filter drain under the vehicle.

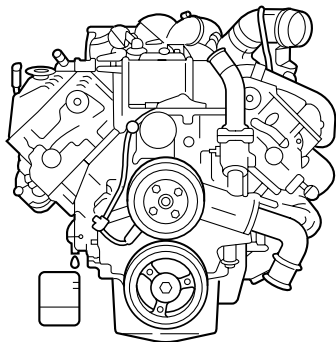

3. Locate the fuel filter drain valve. If necessary, remove the engine appearance cover. Refer to “Engine Compartment” in the *Service points* chapter.

4. **On F-Series and Excursion models**, open fuel filter drain valve by turning clockwise. Allow to drain for approximately 25 seconds or until clean fuel is observed. Close filter drain valve by turning counterclockwise until firmly seated.

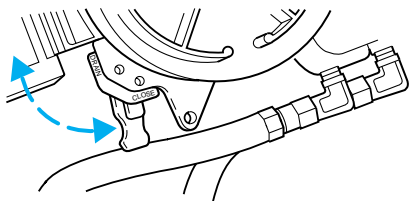

General maintenance information

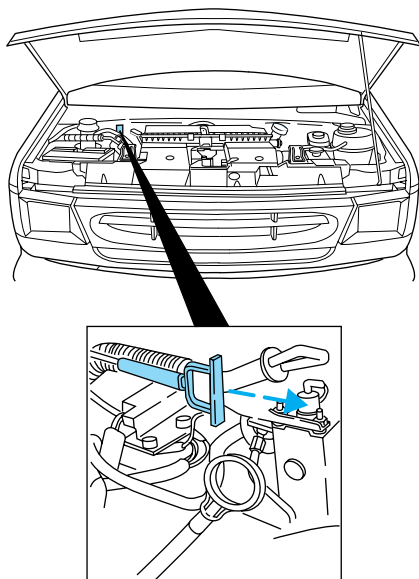

4. **On E-Series models**, open fuel filter drain valve by pulling on the release handle. Allow to drain for approximately 25 seconds or until clean fuel is observed. Close filter drain valve by resetting handle to original position.
5. Verify that the fuel filter drain valve is closed. If removed, install the engine appearance cover.
6. Close the hood and remove the container from under the vehicle.
7. Restart the engine and check WATER IN FUEL indicator light. The light should not glow. If it continues to glow, have fuel system checked and repaired.

ENGINE COOLANT

Checking engine coolant

The concentration and level of engine coolant should be checked at the mileage intervals listed in the scheduled maintenance guide. The coolant concentration should be maintained at 50/50 coolant and water, which equates to a freeze point of -36°C (-34°F). Coolant concentration testing is possible with a hydrometer or antifreeze tester (such as the

General maintenance information

Rotunda Battery and Antifreeze Tester, 014-R1060). The level of coolant should be maintained at the “cold full” of “cold fill range” level in the coolant reservoir. If the level falls below, add coolant per the instructions in the *Adding Engine Coolant* section.

Your vehicle was factory-filled with a 50/50 engine coolant and water concentration. If the concentration of coolant falls below 40% or above 60%, the engine parts could become damaged or not work properly. **A 50-50 mixture of coolant and water provides the following:**

- **freeze protection down to -36° C (-34° F).**
- **boiling protection up to 129° C (265° F).**
- **protection against rust and other forms of corrosion.**
- **enables calibrated gauges to work properly.**

When the engine is cold, check the level of the engine coolant in the reservoir.

- The engine coolant should be at the “cold fill level” or within the “cold fill range” as listed on the engine coolant reservoir (depending upon application).
- Refer to the Scheduled Maintenance Guide for service interval schedules.
- Be sure to read and understand *Precautions when servicing your vehicle* in your owner guide.

If the engine coolant has not been checked at the recommended interval, the engine coolant reservoir may become low or empty. If the reservoir is low or empty, add engine coolant to the reservoir. Refer to *Adding engine coolant* in this chapter.

NOTE: Automotive fluids are not interchangeable; do not use engine coolant, antifreeze or windshield washer fluid outside of its specified function and vehicle location.

Vehicles with diesel engines typically are used to carry heavy loads and accumulate mileage rapidly. These two factors cause the additives in the coolant to “wear out” in a shorter time. Ford recommends an interim service interval performed at 12 months or 24 000 km (15 000 miles), whichever occurs first. Add 237–295 ml (8–10 oz.) of supplemental coolant additive FW-16 to the cooling system. For vehicles with extensive idling time, add 237–295 ml (8–10 oz.) of coolant additive FW-16 after every 500 hours of operation. (see scheduled maintenance guide)

General maintenance information

Adding engine coolant

When adding coolant, make sure it is a 50/50 mixture of engine coolant and distilled water. Add the mixture to the coolant reservoir, **when the engine is cool**, until the appropriate fill level is obtained.



Do not add engine coolant when the engine is hot. Steam and scalding liquids released from a hot cooling system can burn you badly. Also, you can be burned if you spill coolant on hot engine parts.



Do not put engine coolant in the windshield washer fluid container. If sprayed on the windshield, engine coolant could make it difficult to see through the windshield.

The cooling system in your vehicle is filled with either green-colored Motorcraft Premium Engine Coolant meeting Ford specification ESE-M97B44-A or yellow-colored Motorcraft Premium Gold Engine Coolant meeting Ford Specification WSS-M97B51-A1. To determine your vehicle's coolant type (color), check your coolant reservoir.

- **Add Motorcraft Premium Engine Coolant (green-colored), VC-4-A (U.S.) or CXC-10 (Canada) or Motorcraft Premium Gold Engine Coolant (yellow-colored), VC-7-A, depending on the type of coolant originally equipped in your vehicle.** If you are unsure which type of coolant your vehicle requires, check your coolant reservoir or contact your local dealer.
- **Do not add/mix an orange-colored, extended life coolant such as Motorcraft Speciality Orange Engine Coolant, VC-2 (US) or CXC-209 (Canada), meeting Ford specification WSS-M97B44-D with the factory-filled coolant.** Mixing Motorcraft Speciality Orange Engine Coolant or any orange-colored extended life product with your factory filled coolant can result in degraded corrosion protection.
- A large amount of water without engine coolant may be added, in case of emergency, to reach a vehicle service location. In this instance, the cooling system must be drained and refilled with a 50/50 mixture of engine coolant and distilled water as soon as possible. Water alone (without engine coolant) can cause engine damage from corrosion, overheating or freezing.
- **Do not use alcohol, methanol or brine or any engine coolants mixed with alcohol or methanol antifreeze (coolant).** Alcohol and other liquids can cause engine damage from overheating or freezing.

General maintenance information

- **Do not add extra inhibitors or additives to the coolant.** These can be harmful and compromise the corrosion protection of the engine coolant.
- **Do not mix with recycled coolant unless from a Ford-approved recycling process (see *Use of Recycled Engine Coolant* section).**

For vehicles with overflow coolant systems with a non-pressurized cap on the coolant recovery system, add coolant to the coolant recovery reservoir when the engine is cool. Add the proper mixture of coolant and water to the “cold full” level. For all other vehicles, which have a coolant degas system with a pressurized cap, or if it is necessary to remove the coolant pressure relief cap on the radiator of a vehicle with an overflow system, follow these steps to add engine coolant.



To avoid personal injury, make sure the engine is cool before unscrewing the coolant pressure relief cap. The cooling system is under pressure; steam and hot liquid can come out forcefully when the cap is loosened slightly.

1. Before you begin, turn the engine off and let it cool.
2. When the engine is cool, wrap a thick cloth around the coolant pressure relief cap on the coolant reservoir (an opaque plastic bottle). Slowly turn cap counterclockwise (left) until pressure begins to release.
3. Step back while the pressure releases.
4. When you are sure that all the pressure has been released, use the cloth to turn it counterclockwise and remove the cap.
5. Fill the coolant reservoir slowly with the proper coolant mixture (see above), to within the “cold fill range” or the “cold full” level on the reservoir. If you removed the radiator cap in an overflow system, fill the radiator until the coolant is visible and radiator is almost full.
6. Replace the cap. Turn until tightly installed. (Cap must be tightly installed to prevent coolant loss.)

After any coolant has been added, check the coolant concentration see Checking Engine Coolant section). If the concentration is not 50/50 (protection to $-34^{\circ}\text{F}/-36^{\circ}\text{C}$), drain some coolant and adjust the concentration. It may take several drains and additions to obtain a 50/50 coolant concentration.

Whenever coolant has been added, the coolant level in the coolant reservoir should be checked the next few times you drive the vehicle. If necessary, add enough 50/50 concentration of engine coolant and distilled water to bring the liquid level to the proper level.

General maintenance information

If you have to add more than 1.0 liter (1.0 quart) of engine coolant per month, have your dealer check the engine cooling system. Your cooling system may have a leak. Operating an engine with a low level of coolant can result in engine overheating and possible engine damage.

Replacing coolant

A coolant mixture of 50% coolant concentrate and 50% water is recommended to maintain best overall performance. To avoid damaging the engine and radiator, the coolant concentrate should not exceed 60%. When refilling the coolant system either as part of the regular maintenance (refer to the scheduled maintenance guide), or due to service performed, adhere to the following instructions:

1. Drain and flush the cooling system to remove dirt deposits, oil, rust particles.

NOTE: When filling the system with Motorcraft Premium Engine Coolant (green-colored) or equivalent meeting Ford specification ESE-M97B44-A, a supplemental coolant additive is required. Refer to *Adding Coolant* section to determine the coolant type in your vehicle. Add 1.89L (4 pints) of Motorcraft Heavy Duty Cooling System Additive FW-16 or equivalent meeting Ford specification ESN-M99B169-A, directly to the cooling system. An additional 237–295 ml (8–10 oz.) of supplemental coolant additive FW-16 should be added at 24 000 km (15 000 mile) intervals to maintain proper concentration. **Do not use this additive with yellow-colored coolant meeting Ford specification WSS-M97B51-A1.**

2. Fill the coolant reservoir with the specified coolant/water mixture until the level stabilizes at the top hose fitting. Replace and tighten cap. Fill the coolant bottle to the cold fill mark.

3. Reinstall the coolant bottle cap.

4. Start and idle engine until the radiator upper hose is warm (approximately 10–15 minutes). If the hose does not get warm then repeat at a higher engine speed.

5. Immediately shut off engine. Cautiously remove coolant bottle cap and add coolant to Cold Fill mark.

Recycled engine coolant

Ford Motor Company recommends the use of a recycled engine coolant produced by Ford-approved processes in vehicles originally equipped with Motorcraft Premium Engine Coolant (green-colored). However, not all coolant recycling processes produce coolant that meets Ford

General maintenance information

specification ESE-M97B44-A. Use of such coolant may harm the engine and cooling system components.

Ford Motor Company does NOT recommend the use of recycled engine coolant in vehicles originally equipped with Motorcraft Premium Gold Engine Coolant since a Ford-approved recycling process is not yet available.



Used engine coolant should be disposed of in an appropriate manner. Follow your community's regulations and standards for recycling and disposing of automotive fluids.

Coolant refill capacity

To find out how much fluid your vehicle's cooling system can hold, refer to *Refill capacities* in this chapter.

Fill your engine coolant reservoir as outlined in *Adding engine coolant*.

Severe climates

If you drive in extremely cold climates (less than -36°C [-34°F):

- **it may be necessary to increase the coolant concentration above 50%.**
- **NEVER increase the coolant concentration above 60%.**
- **increased engine coolant concentrations above 60% will decrease the overheat protection characteristics of the engine coolant and may cause engine damage.**
- **refer to the chart on the coolant container to ensure the coolant concentration in your vehicle will provide adequate freeze protection at the temperatures in which you drive in the winter months.**

If you drive in extremely hot climates:

- **it is still necessary to maintain the coolant concentration above 40%.**
- **NEVER decrease the coolant concentration below 40%.**
- **decreased engine coolant concentrations below 40% will decrease the corrosion protection characteristics of the engine coolant and may cause engine damage.**
- **decreased engine coolant concentrations below 40% will decrease the freeze protection characteristics of the engine coolant and may cause engine damage.**

General maintenance information

- **refer to the chart on the coolant container to ensure the coolant concentration in your vehicle will provide adequate protection at the temperatures in which you drive.**

Vehicles driven year-round in non-extreme climates should use a 50/50 mixture of engine coolant and distilled water for optimum cooling system and engine protection.

Coolant conditioner (liquid)

For engines filled with green-colored Motorcraft Premium Engine Coolant, a supplemental coolant additive FW-16 meeting Ford specification ESN-M99B169-A has been added to the coolant in this engine.

This additive aids in the prevention of rust and scale buildup on the internal parts of the cooling system. Prevention of rust and scale buildup allows for proper dissipation of heat generated by combustion.

See the “scheduled maintenance guide” for recommended intervals.

EMISSION CONTROL SYSTEM(S) LAWS

Federal law prohibits vehicle manufacturers, dealers and other persons engaged in the business of repairing, servicing, selling, leasing or trading motor vehicles as well as fleet operations from unknowingly removing or rendering emission control system(s) inoperative. Further, modifications of the emission control system(s) could create liability on the part of the individual owners under the laws of some states. In Canada, modifications of the emission control system(s) could create liability under applicable Federal or Provincial laws.

Do not remove or alter the original equipment floor covering or insulation between it and the metal floor of the vehicle. The floor covering and insulation protect occupants of the vehicle from the engine and exhaust system heat and noise. On vehicles with no original equipment floor covering insulation, do not carry passengers in a manner that permits prolonged skin contact with the metal floor. Provide adequate insulation.

NOISE EMISSIONS WARRANTY, PROHIBITED TAMPERING ACTS AND MAINTENANCE

On January 1, 1978, Federal regulation became effective governing the noise emission on trucks over 4 536 kg (10 000 lbs.) GVWR (Gross Vehicle Weight Rating). The following statements concerning prohibited tampering acts and maintenance, and the noise warranty found in the Warranty Facts Booklet, are applicable to complete chassis cabs over 4 536 (10 000 lbs.) GVWR.

General maintenance information

Tampering with noise control system prohibited

Federal law prohibits the following acts or the causing thereof: (1) The removal or rendering inoperative by any person other than for purposes of maintenance, repair or replacement of any device or element of design incorporated into any new vehicle for the purpose of noise control prior to its sale or delivery to the ultimate purchaser or while it is in use, or (2) the use of the vehicle after such device or element of design has been removed or rendered inoperative by any person.

Among those acts which the U.S. Environmental Protection Agency may presume to constitute tampering are the acts listed below:

- Removal of hood blanket, fender apron absorbers, fender apron barriers, underbody noise shields or acoustically absorptive material.
- Tampering or rendering inoperative the engine speed governor, so as to allow engine speed to exceed manufacturer's specifications.

Scheduled maintenance

VEHICLE EMISSIONS CONTROL INFORMATION (VECI)

Emissions information appears on the VECI decal on the engine valve cover. This decal identifies engine displacement and provides certain engine specifications.

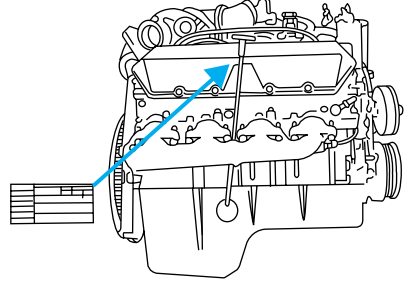

SCHEDULED MAINTENANCE SERVICES

Refer to your scheduled maintenance guide for details of maintenance on your vehicle.

If you are using your vehicle in a manner in which it will remain stationary (door to door service, taxi, etc.), then it is recommended that you change the engine oil every 200 engine hours as opposed to a mileage limit. Since most vehicles are not equipped with hourmeters, it may be necessary for you to approximate your time and plan engine oil and filter changes accordingly.

Any modification of the emissions control system could create liability under federal law (U.S.) if made prior to sale and registration, under the laws of some states if made thereafter. Further, federal law prohibits vehicle manufacturers, dealers and other persons engaged in the business of repairing, servicing, selling, leasing or trading motor vehicles as well as fleet operations from knowingly removing or rendering an emissions control system inoperative after sale and delivery to an ultimate purchaser. In Canada, modifications of the emissions control system could create liability under applicable federal or provincial laws.

Minor troubleshooting guide

The complexity of the diesel engine makes it so the owner is discouraged from attempting to perform maintenance other than the services described in this supplement.

If you experience difficult starting, rough idling, excessive exhaust smoke, a decrease in engine performance or excess fuel consumption, perform the following checks:

- a plugged air inlet system or engine air filter element.
- water in the fuel filter/water separator.
- a clogged fuel filter.
- contaminated fuel.
- air in the fuel system, due to loose connections.
- an open or pinched sensor hose.
- low engine oil level.
- wrong fuel for climactic conditions.

If these checks do not help you correct the engine performance problem you are experiencing, consult an authorized dealer.

FUELING



Do not use starting fluid such as ether or gasoline in the diesel air intake system. Such fluids can cause immediate explosive damage to the engine and possible personal injury.

If you fuel your vehicle at a truck stop, you may notice that the fuel nozzle may shut off every 5–10 seconds. This is due to the flow rates being designed for larger heavy duty trucks. You may have to fuel at a slower rate (don't depress the nozzle trigger fully).

Do not run your diesel vehicle out of fuel as this will allow air to enter the fuel system which will make restarting difficult. Longer engine cranking time may be required once air is in the fuel system. If air enters the fuel system (either through running the fuel tank(s) empty or during a fuel filter change), the engine will self-purge the trapped air once it starts running. The engine may run roughly and produce white smoke while air is in the fuel system; this is normal and should stop after a short time.

Minor troubleshooting guide

IF THE ENGINE WON'T CRANK

Turn on the headlights. If the lights are dim, do not go on at all or if when the ignition is turned to START the lights become dim or go out, the battery connections may be loose or corroded, or the battery may be discharged. If there is a clicking or stuttering sound coming from the engine compartment when you turn the key to START, this may also indicate a loose or corroded battery connection.

Check the battery connections at the battery posts, cable connection to the engine grounding point and at the starter relay terminals. Also, make sure the relay bracket is securely fastened to its mounting surface.

If the starter relay clicks, but the starter does not crank, check the connections at the starter terminal. If a discharged battery is suspected, have it checked and corrected.

- For vehicles with manual transmissions, the clutch pedal **must** be fully depressed in order for the starter to operate.
- For vehicles with automatic transmissions, the gearshift lever must be in Park or Neutral in order for the starter to operate.
- Try operating the starter switch several times. Should the switch be corroded, this operation may clean the contacts or make the switch temporarily operable until you can reach the dealer.
- If all electrical connections are tight and you need assistance to start, see “Jump Starting Your Vehicle”.

IF ENGINE CRANKS BUT WON'T START

Prolonged starter cranking (in excess of 30 seconds) could cause damage to the starter motor.

- Check the fuel gauge. You may be out of fuel. If the gauge shows that there is fuel in the tank, the trouble may be in the electrical system or the fuel system. If equipped with an auxiliary tank, be sure that the tank control switch is set for the tank with fuel and not on an empty tank.
- Leaving the ignition key ON for over two minutes without starting may make starting difficult because the glow plugs will cease activation. Reset the system by turning the ignition key to OFF and then back to ON again.

Minor troubleshooting guide

IF THE ENGINE RUNS HOT

The following could cause the engine to overheat:

- Lack of coolant.
- Dirty cooling system.
- Driving with frozen coolant.
- Sticking thermostat.
- Overloading or pulling heavy trailers during hot weather.
- Grill or radiator air blockage.
- Slipping or missing drive belt.
- Plugged or very dirty air cleaner element.

IF FUSES BURN OUT

Burned-out or blown fuses usually indicate an electrical short-circuit, although a fuse may occasionally burn out from vibration. Insert a second fuse. If this fuse immediately burns out and you cannot locate the cause, return your vehicle to your dealer for a circuit check.



Replacement fuses and circuit breakers must always be the same rating as the original equipment shown. Never replace a fuse or circuit breaker with one of a higher rating. Higher rated fuses or circuit breakers could allow circuit overloading in the event of a circuit malfunction, resulting in severe vehicle damage or personal injury.

Refer to the “Owner Guide” for replacement of fuses.

Capacities and specifications

REFILL CAPACITIES

Component	Capacity
Cooling system (E-Series) ^{1, 2, 3}	28.5L (30.0 quarts)
Cooling system (F-Series and Excursion) ^{1, 3}	31.0L (32.75 quarts)
Engine oil ⁴	14.2 L (15.0 quarts)
Fuel tank (F-Series)	Refer to Owner Guide
Fuel tank (Excursion)	166.6L (44.0 gallons)
Fuel tank (E-Series) ⁵	132.5L (35.0 gallons)
Radiator cap	90 kPa (13 psi)
Manual transmission ⁶	5.5L (5.8 quarts)
Automatic transmission	Refer to Owner Guide

¹Includes heater and 4.7L (5 quarts) in coolant recovery.

²Add 2.5L (2.6 quarts) if equipped with auxiliary heater option.

³Add the coolant type originally equipped in your vehicle. For vehicles filled with Motorcraft Premium Engine Coolant (green-colored) add 1.89L (4 pints) of supplemental coolant additive, FW-16 or equivalent, meeting Ford Specification ESN-M99B169-A.

⁴Includes 1.9L (2 quarts) in engine oil filter.

⁵Optional DRW cutaway and all standard E-450 models are 208.2L (55.0 gallons).

⁶Use Motorcraft MERCON® ATF, Motorcraft part number XT-2-QDX, meeting Ford specification MERCON®.

BULB SPECIFICATIONS

Lamp description	Number of bulbs required	Trade number
Wait to Start Light	1	194
Water-in-Fuel Light	1	194
Engine Temp. Light	1	194

Capacities and specifications

LUBRICANT AND MAINTENANCE MATERIALS SPECIFICATIONS

Item	Ford Part Name	Ford Part Number	Ford Specification
Engine Oil	Motorcraft Motor Oil 15W40 Super Duty, 10W30 Super Duty	XO-15W40-QSD, XO-10W30-QSD	WSS-M2C171-C, CH-4/SJ
Engine Oil Filter (Use this filter Only)	-	F4TZ-6731-A (FL-1995)	-
Air Filter (F-Series and Excursion) ¹	-	FA-1680	ES-E95AE-9601-AA
Air Filter (E-Series) (2 Required)	-	FA-1618	ES-E95AE-9601-AA
Battery (2 Required)	-	BXT-65-750	-
Engine Coolant	Motorcraft Premium Engine Coolant (green-colored)	VC-4-A (US) or CXC-10 (Canada)	ESE-M97B44-A
	Motorcraft Premium Gold Engine Coolant (yellow-colored)	VC-7-A	WSS-M97B51-A1
Engine Coolant Additive ²	Motorcraft Heavy Duty Cooling System Additive	FW-16	ESN-M99B169-A
Manual Transmission	Motorcraft MERCON® ATF	XT-2-QDX	MERCON®

¹Always use the authorized Motorcraft air filter listed.



Failure to use the correct air filter may result in severe engine damage.

²Use only when filling with Motorcraft Premium Engine Coolant (green-colored).

ENGINE COMPARTMENT

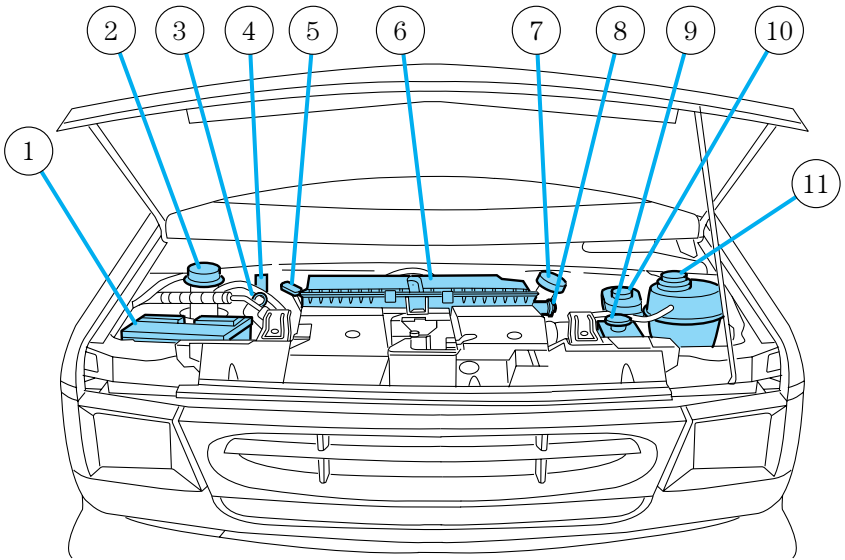

1. Battery
2. Windshield washer fluid reservoir
3. Engine oil dipstick
4. Fuel filter/water separator drain valve release handle
5. Automatic transmission fluid dipstick
6. Air filter assembly
7. Engine oil filler
8. Air filter restriction gauge
9. Power steering fluid reservoir
10. Brake fluid reservoir
11. Engine coolant recovery reservoir

Service points

F-SERIES AND EXCURSION ENGINE COMPARTMENT

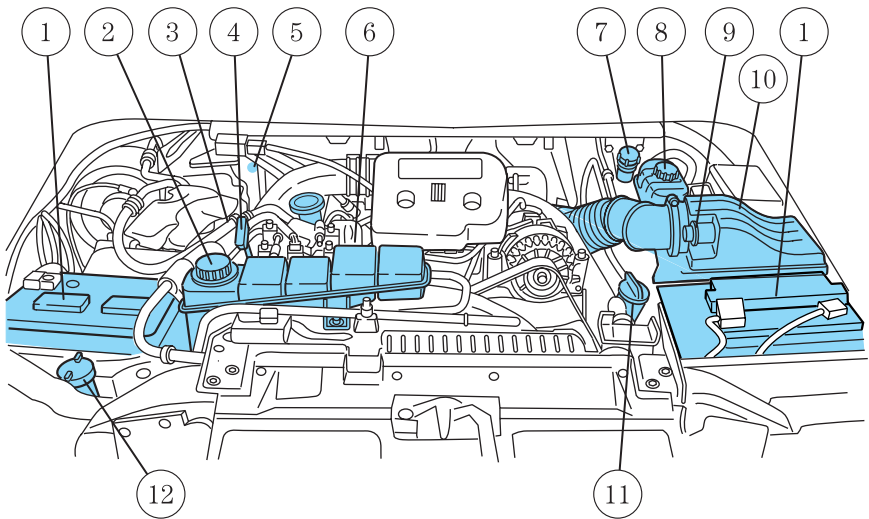

1. Battery (dual batteries shown)
2. Engine coolant recovery reservoir
3. Engine oil filler
4. Engine oil dipstick
5. Automatic transmission dipstick (if equipped)
6. Fuel filter drain valve
7. Clutch fluid reservoir (if equipped)
8. Brake fluid reservoir
9. Air filter restriction gauge
10. Air filter assembly
11. Power steering fluid reservoir
12. Windshield washer fluid reservoir