

**FORD:** 1999-2004 F-350, F-450, F-550

This article supersedes TSB **99-08-2** to update the vehicle model years.

### **ISSUE**

There may be a steering wheel fight after hitting bumps or ruts in the road on some vehicles. This may be caused by steering geometry and/or vehicle loads.

### **ACTION**

Install a steering damper on vehicles if the damper was not factory installed. The damper will help control steering linkage and reduce the possibility of wheel fight. Refer to the following Service Procedure for details.

### **SERVICE PROCEDURE**

#### **DEFINITION**

Some regular cab F-350/450/550 chassis cabs may exhibit wheel fight when the front tires encounter a road irregularity such as a pothole. Wheel fight results in a slight single jerk (5-10 degrees) of the steering wheel and should not be confused with wheel shimmy. Wheel shimmy results in a continual oscillation (5-10 degrees in each direction) of the steering wheel and usually can only be controlled by bringing the vehicle to a complete stop.

#### **INSTALLATION INSTRUCTIONS**

##### **F-350 4X2**

1. Mount Frame Damper Bracket (F81Z-3E652-AB) to right forward side of front crossmember using two (2) M12x70 Bolts (N606084-S426) with two (2) M12 Nuts (N620483-S301).
2. Torque to 90 N•m (66 lb-ft) (refer to Figure 1).
3. Mount Tie Rod Damper Bracket (F81Z-3E652-DA) to the bottom back side of the tie rod at the "V" with the damper mounting hole of the bracket orientated up and 45 degrees to the rear. The bracket should be positioned with the bracket edge 40mm (1.57") from the drag link ball stud (refer to Figure 2).

4. Use two (2) M8 U-bolts (N811596-S426) with four (4) M8 Nuts (N620481-S301) and torque to 28 N•m (21 lb-ft).
5. Mount the piston end of Steering Damper (F7UZ-3E651-AB) to frame bracket and cylinder end to tie rod bracket using two (2) M12x70 Bolts (N606084-S426) and two (2) M12 Nuts (N620483-S301). Torque to 90 N•m (66 lb-ft) (refer to Figure 1).
6. Cycle the steering wheel full left and right turns to ensure all damper components have clearance to other components and that the damper piston does not bottom out. The damper cylinder clearance to the front crossmember in full right turn should be no less than 6mm (0.25").

##### **F-350 4X4**

1. Locate the set of four (4) grooves stamped in the tie rod.
2. Mount the Tie Rod Damper Bracket (F81Z-3E652-AA) to the forward side of the tie rod at the left most pair of grooves with the bracket directed downward and the bracket part number facing forward (refer to Figure 3).
3. Use two (2) M10 U-bolts (N811656-S426) and four (4) M10 Nuts (N620482-S301) and torque to 60 N•m (44 lb-ft) (refer to Figure 4).
4. Mount the cylinder end of Steering Damper (F81Z-3E651-DA) to frame bracket and piston end to tie rod bracket using two (2) M12x70 Bolts (N606084-S426) and two (2) M12 Nuts (N620483-S301). Torque to 90 N•m (66 lb-ft) (refer to Figure 4).
5. Cycle the steering wheel full left and right turns to ensure all damper components have clearance to other components and that the damper piston does not bottom out.

##### **F-450/550 4X2 And 4X4**

1. Locate the set of four (4) grooves stamped in the tie rod.

**NOTE:** The information in Technical Service Bulletins is intended for use by trained, professional technicians with the knowledge, tools, and equipment to do the job properly and safely. It informs these technicians of conditions that may occur on some vehicles, or provides information that could assist in proper vehicle service. The procedures should not be performed by "do-it-yourselfers". Do not assume that a condition described affects your car or truck. Contact a Ford, Lincoln, or Mercury dealership to determine whether the Bulletin applies to your vehicle.

## Article No. 03-17-4 Cont'd.

2. Mount the Tie Rod Damper Bracket (F81Z-3E652-AA) to the forward side of the tie rod at the right most pair of grooves with the bracket directed downward and the bracket part number facing forward (refer to Figure 5).
3. Use two (2) M10 U-bolts (N811656-S426) and four (4) M10 Nuts (N620482-S301). Torque to 60 N•m (44 lb-ft) (refer to Figure 4).
4. Mount the cylinder end of Steering Damper (F81Z-3E651-DA) to frame bracket and piston end to tie rod bracket using two (2) M12x70 Bolts (N606084-S426) and two (2) M12 Nuts (N620483-S301). Torque to 90 N•m (66 lb-ft) (refer to Figure 4).
5. Cycle the steering wheel full left and right turns to ensure all damper components have clearance to other components and that the damper piston does not bottom out.

PART NUMBER	PART NAME
F81Z-3E652-AA	Bracket - Tie Rod Damper (F-350 4X4 And F-450/550 4X2/4X4)

**OTHER APPLICABLE ARTICLES:** NONE

**SUPERSEDES:** 99-08-2

**WARRANTY STATUS:** Eligible Under The Provisions Of Bumper To Bumper Warranty Coverage

OPERATION	DESCRIPTION	TIME
031704A	Install Steering Damper - F-350 4X2	0.5 Hr.
031704B	Install Steering Damper - F-350 4X4 And F-450/550 4X2/4X4	0.4 Hr.

### DEALER CODING

BASIC PART NO.  
3E651

CONDITION  
CODE  
42

PART NUMBER	PART NAME
F7UZ-3E651-AB	Damper - Steering (F-350 4X2)
F81Z-3E651-DA	Damper - Steering (F-350 4X4 And F-450/550 4X2/4X4)
F81Z-3E652-AB	Bracket - Frame Damper (F-350 4X2)
N606084-S426	Bolt - M12x70 (All)
N811808-S426	Retainer (4X2)
N811596-S426	U-Bolt (4X2)
N811656-S426	U-Bolt - M10 (4X4)
N620481-S301	Nut - M8 (4X2)
N620482-S301	Nut - M10 (4X4)
N620483-S301	Nut - M12 (All)
F81Z-3E652-DA	Bracket - Tie Rod Damper (F-350 4X2)

(Cont'd.)

F-350 4X2

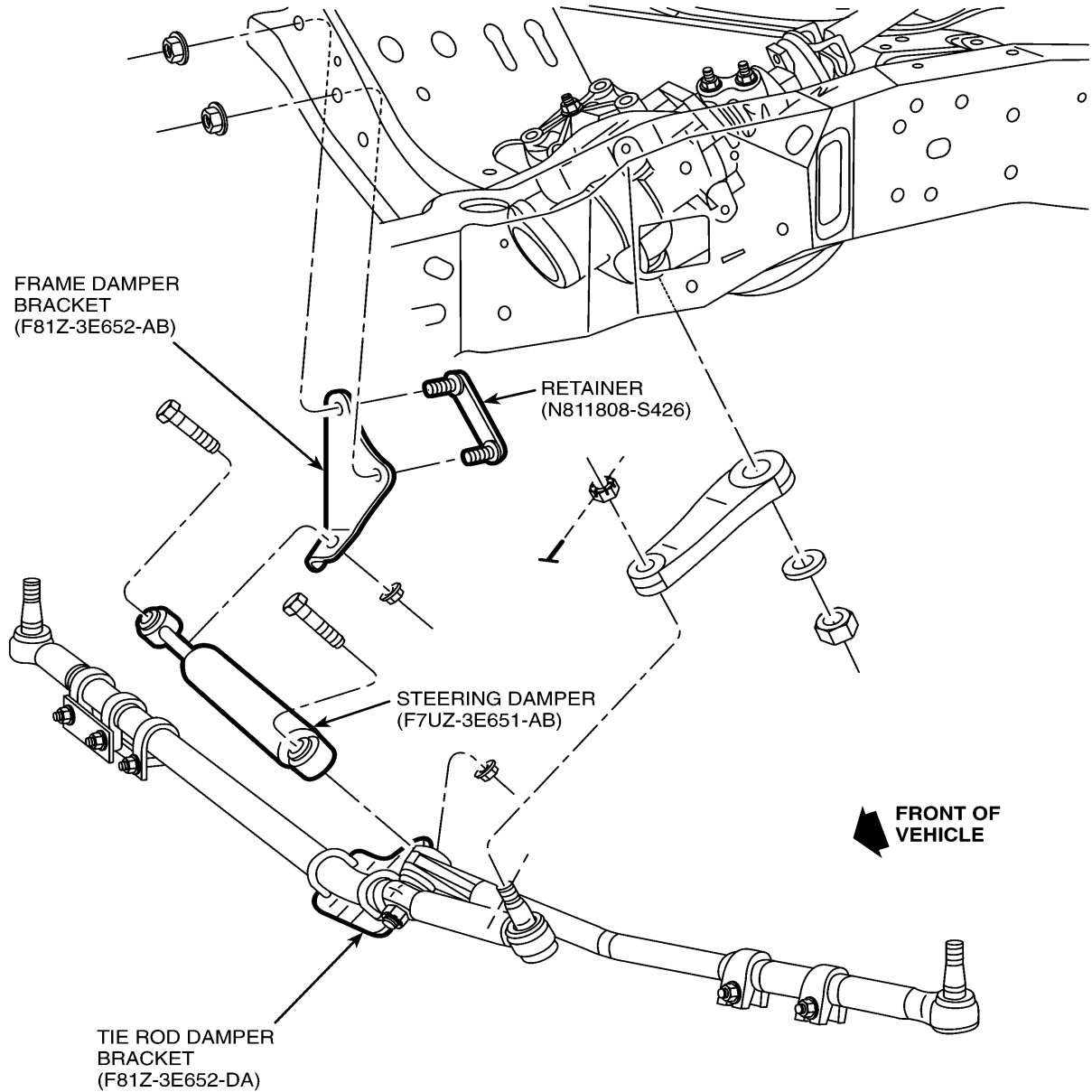

TB-5689-A

Figure 1 - Article 03-17-4

F-350 4X2

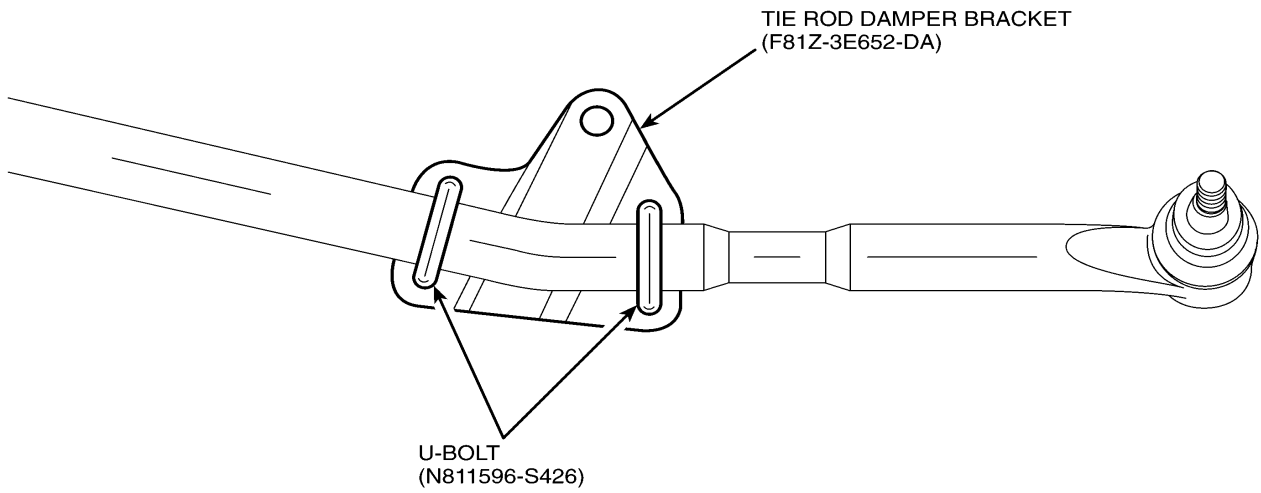

TB-5690-A

Figure 2 - Article 03-17-4

F-350 4X4

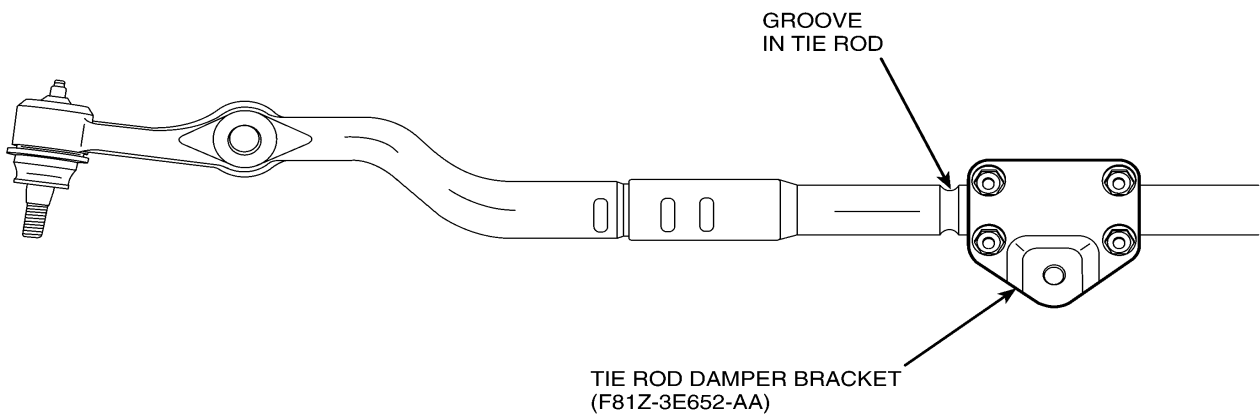

TB-5691-A

Figure 3 - Article 03-17-4

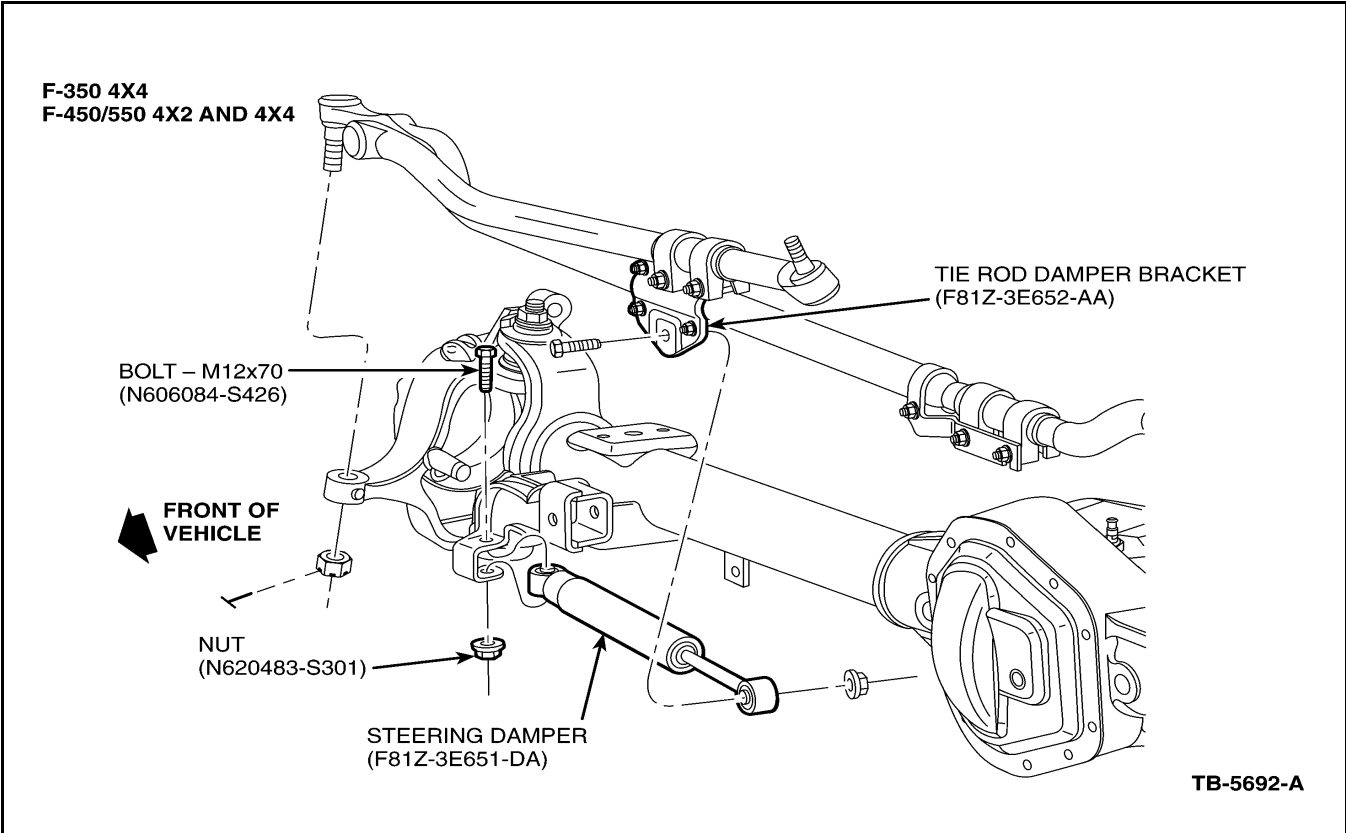

Figure 4 - Article 03-17-4

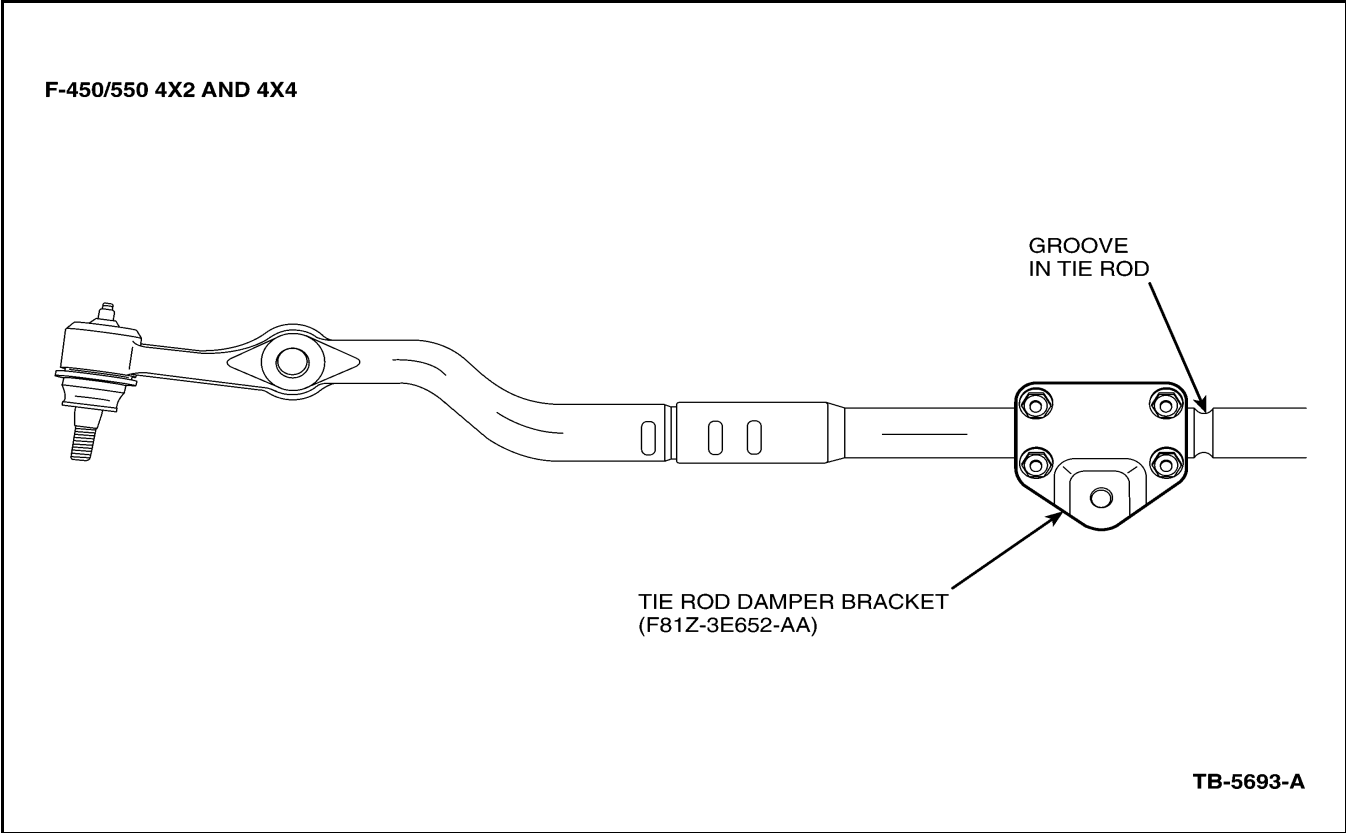

Figure 5 - Article 03-17-4