

TRANSMISSION—E4OD—UPGRADE—BALL BEARING CENTER SUPPORT SERVICE KIT

Article No.
94-24-15

FORD: 1989-1994 BRONCO, E SERIES, F SUPER DUTY, F-150-350 SERIES

ISSUE

A service kit for upgrading 1989-94 E4OD transmissions with the 1995 ball bearing center support components has been released for service.

ACTION

Install the new service kit when any of the following components require replacement in the transmission:

- center support
- center shaft
- output shaft

And/or any of the following bushings show wear:

- case bushings
- sun gear bushing
- output shaft bushing (located at the end of the output shaft)
- or if the inner diameter of the center support shows wear.

Refer to the following service procedure.

- When using this kit, all components must be used unless otherwise stated in the instructions.
- Do not use this kit for service on 1995 model transmissions. The components in this kit are unique and will only service 1989-94 E4OD transmissions.

The kit consists of the following (refer to Figure 1):

- 1 (one) Ball Bearing Center Support Assembly
- 1 (one) Overdrive Center Shaft
- 1 (one) #5 Needle Bearing
- 1 (one) Orificed Cup
- Instruction Sheet #6712

KIT INSTALLATION INSTRUCTIONS

Follow all the normal service procedures associated with disassembly, cleaning/inspection and reassembly as outlined in the Service Manual, Section 07-01A, when installing this kit.

After the transmission has been disassembled, follow these steps.

NOTE

IF THE OUTPUT SHAFT IS ALREADY EQUIPPED WITH A CUP PLUG, DO NOT USE THE CUP PLUG FROM THIS KIT. ONLY USE THE CUP PLUG IN THIS KIT IF THE OUTPUT SHAFT HAS A REMOVABLE BUSHING.

If the output shaft is not damaged and is reusable:

1. Remove the output shaft bushing from the end of the output shaft using a slide hammer with collar (33858) and actuator pin (28253) from the blind hole puller set (D80L-100-A). Refer to Figure 2.
2. Using a mallet and output shaft bushing replacer (T93T-77060-A), install the orificed cup plug (391590-S) from this kit. Refer to Figure 3.

NOTE

ENSURE CUP PLUG SEATS BELOW THE SURFACE OF THE OUTPUT SHAFT END (FIGURE 4). WHEN THE TOOL BOTTOMS OUT ON THE OUTPUT SHAFT, THE CUP PLUG IS SEATED BELOW THE OUTPUT SHAFT END.

During disassembly and assembly of the subassemblies, perform the following steps:

3. Remove the retaining ring from the overdrive ring gear.
4. Remove the overdrive center shaft and discard.
5. Install the new overdrive center shaft (7A658) from the service kit and install the retaining ring. Refer to Figure 5.

NOTE

IT MAY NOT BE NECESSARY TO REPLACE THE OVERDRIVE PLANET OR INPUT SHAFT WHEN USING THIS KIT. THE OVERDRIVE CENTER SHAFT KIT (F4TZ-7A130-B) WILL WORK WITH THE LONG OR SHORT OVERDRIVE PLANET CARRIER AND INPUT SHAFT. REFER TO FIGURE 6. IF REPLACING JUST THE OVERDRIVE PLANET OR INPUT SHAFT, KIT F4TZ-7B446-B MUST BE USED.

During reassembly of the transmission, perform the following steps:

Article No. 94-24-15 Cont'd.

6. Install ball bearing center support from service kit. Discard original center support.
7. Install #5 needle bearing (7G178) from the kit.
8. Install overdrive ring gear and center shaft into the transmission.

CAUTION

SOME 1994 MODEL YEAR TRANSMISSIONS WERE BUILT WITH SOME OR ALL OF THE PARTS THAT RESEMBLE PARTS IN THIS KIT, AND MAY OR MAY NOT HAVE A #5 NEEDLE BEARING (7G178). WHEN SERVICING THESE TRANSMISSIONS, USE ALL PARTS IN THIS KIT EXCEPT THE CUP PLUG. THESE TRANSMISSIONS ALREADY HAVE A CUP PLUG IN THE OUTPUT SHAFT. THE SERVICE CUP PLUG IN THIS KIT WILL ONLY FIT OUTPUT SHAFTS THAT HAD A BUSHING.

- Do not mix removed parts with kit parts.
- Ensure the #5 needle bearing from this kit is installed.
- Follow all the normal service procedures associated with disassembly/reassembly as outlined in the Service Manual, Section 07-01A.
- If servicing the overdrive planet assembly and input shaft during installation of this kit, remember that they are mating components and must be serviced together.

9. After the pump is installed and the input shaft has been inserted into the transmission, a measurement can verify the correct input shaft and overdrive planet assembly were used. The input shaft must extend 1.5" (38mm) past the end of the pump stator. This measurement will verify the correct input shaft and overdrive planet assembly has been used.

PART NUMBER	PART NAME
F4TZ-7A130-B	Service Kit
F4TZ-7B446-B	Overdrive Planet Kit

OTHER APPLICABLE ARTICLES: NONE
WARRANTY STATUS: INFORMATION ONLY
OASIS CODES: 501000, 502000, 503000, 504000

NOTE: THE LETTER "S" COULD BE IN EITHER LOCATION. THE "S" INDICATES SERVICE PART.

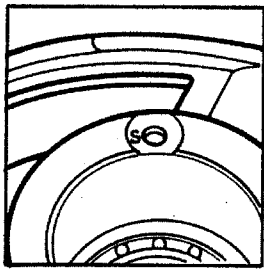
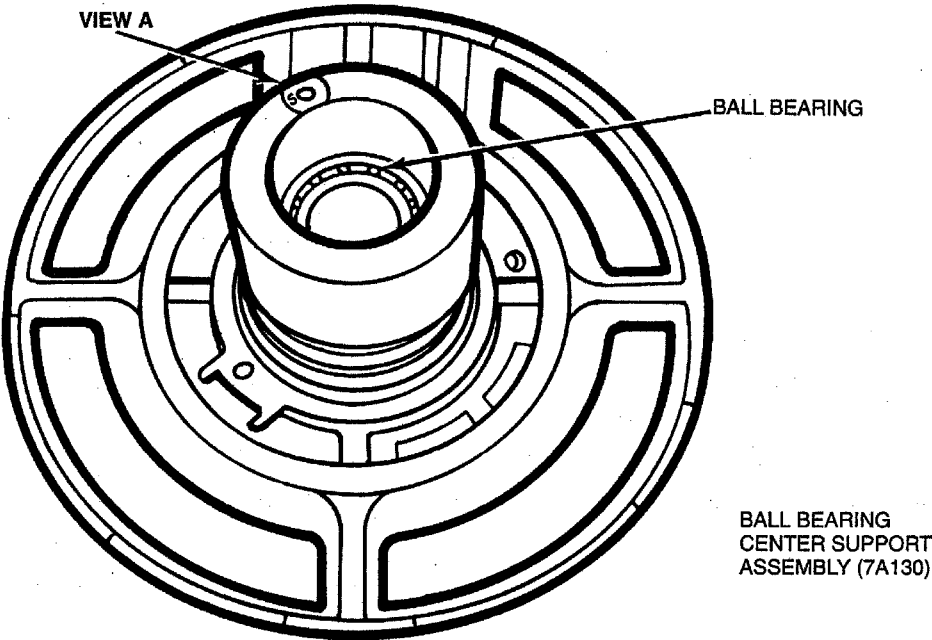
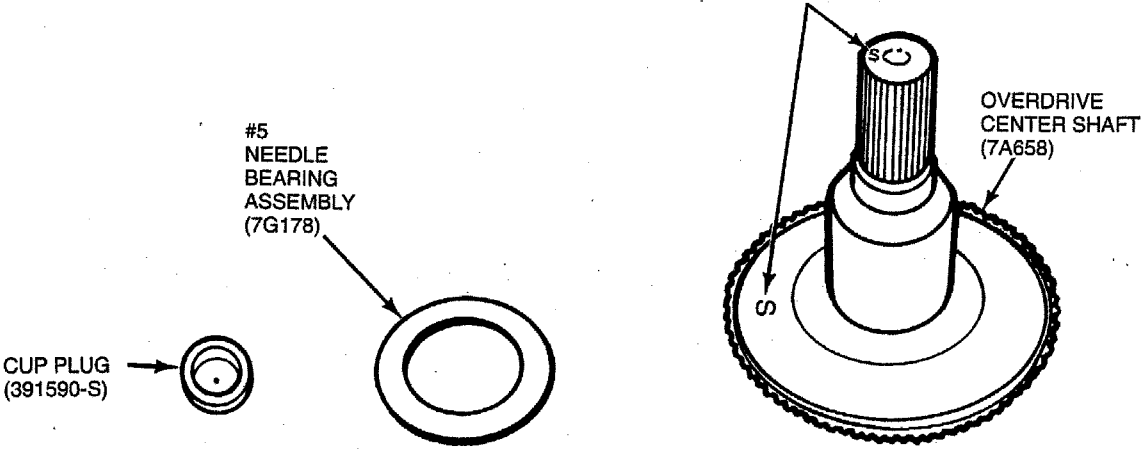

VIEW A
LETTER "S" INDICATES SERVICE KIT PART

Figure 1 - Article 94-24-15

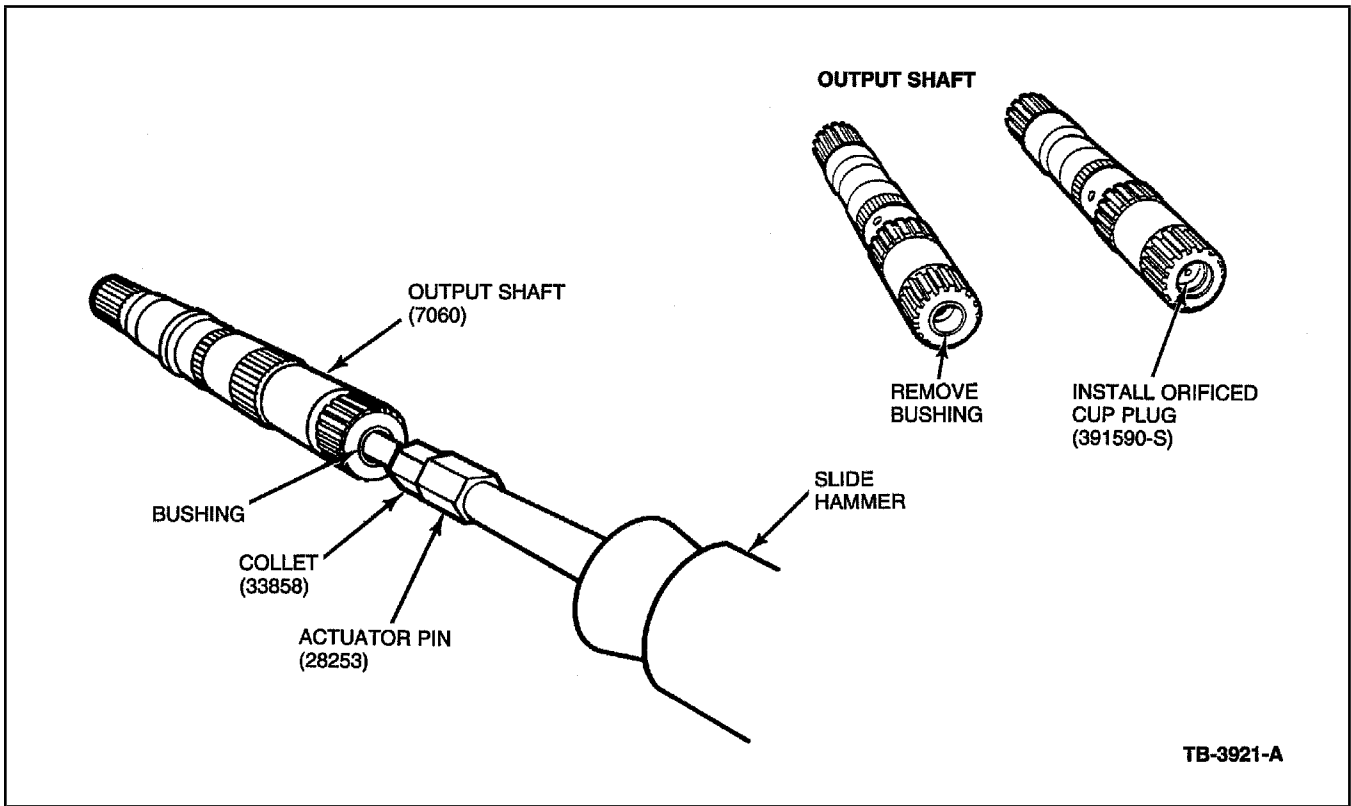

Figure 2 - Article 94-24-15

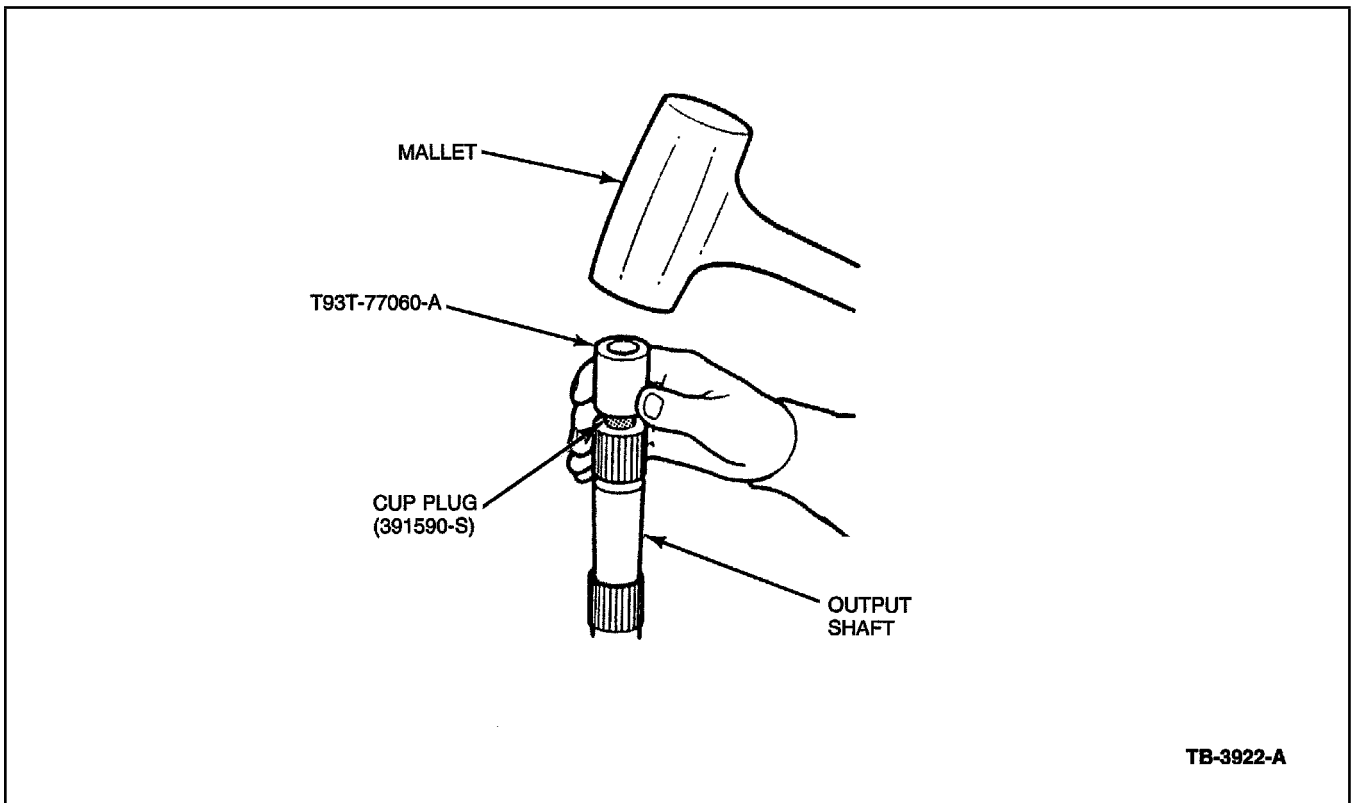

Figure 3 - Article 94-24-15

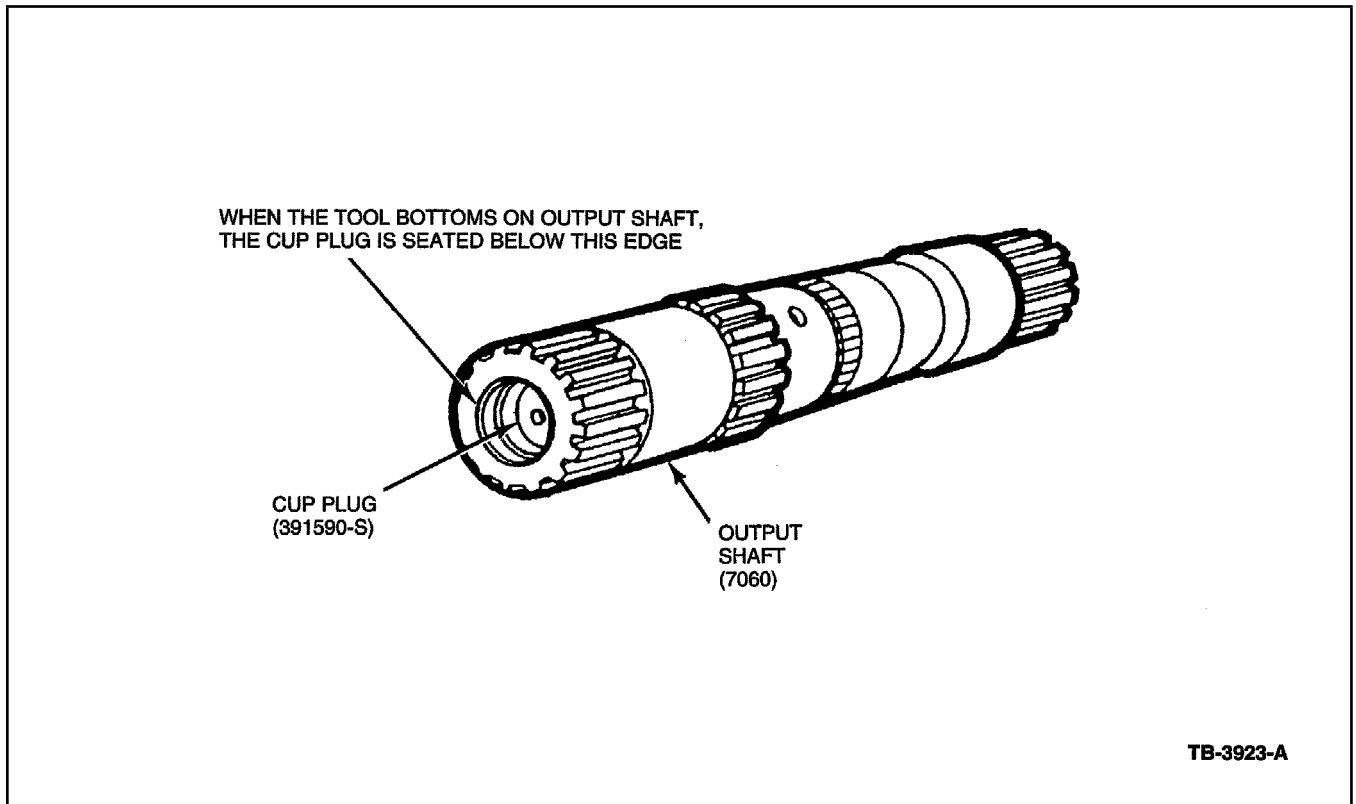

Figure 4 - Article 94-24-15

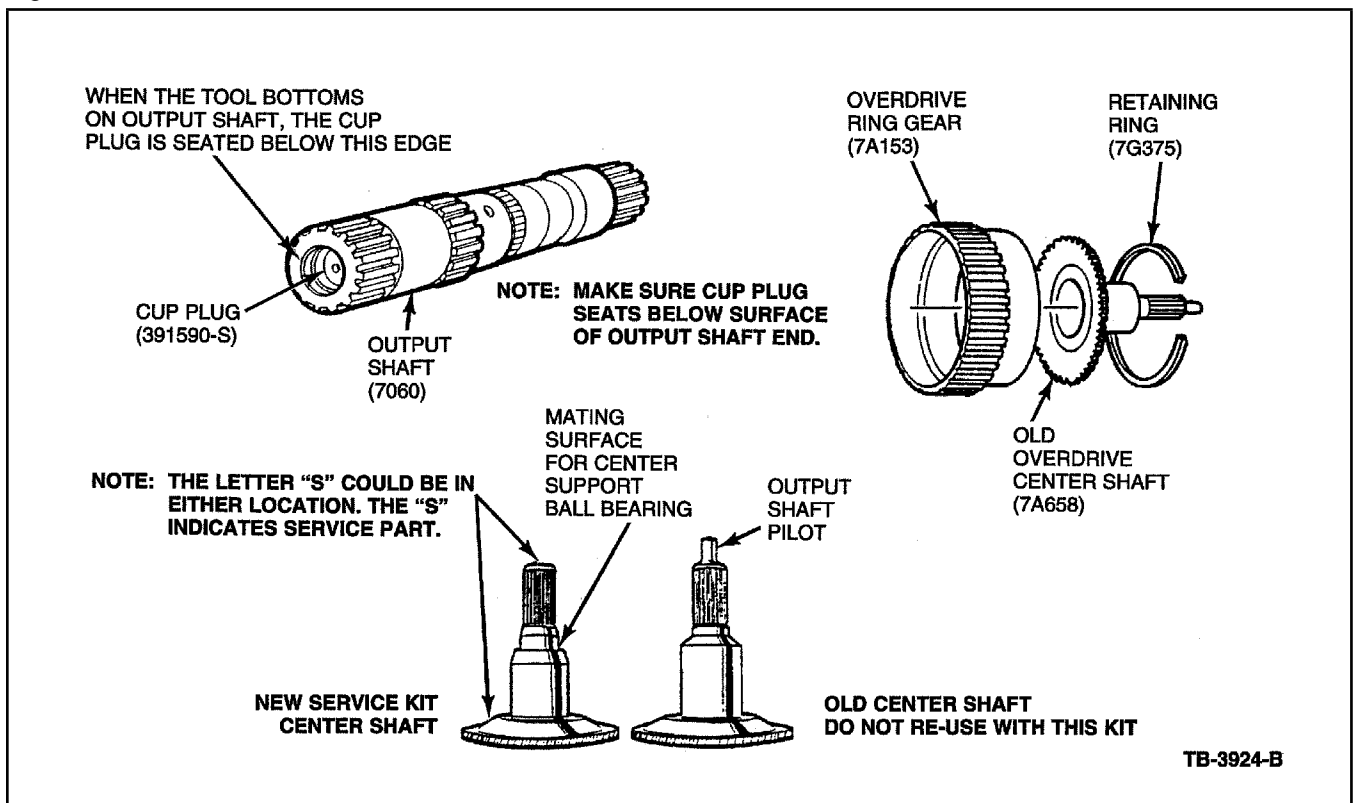

Figure 5 - Article 94-24-15

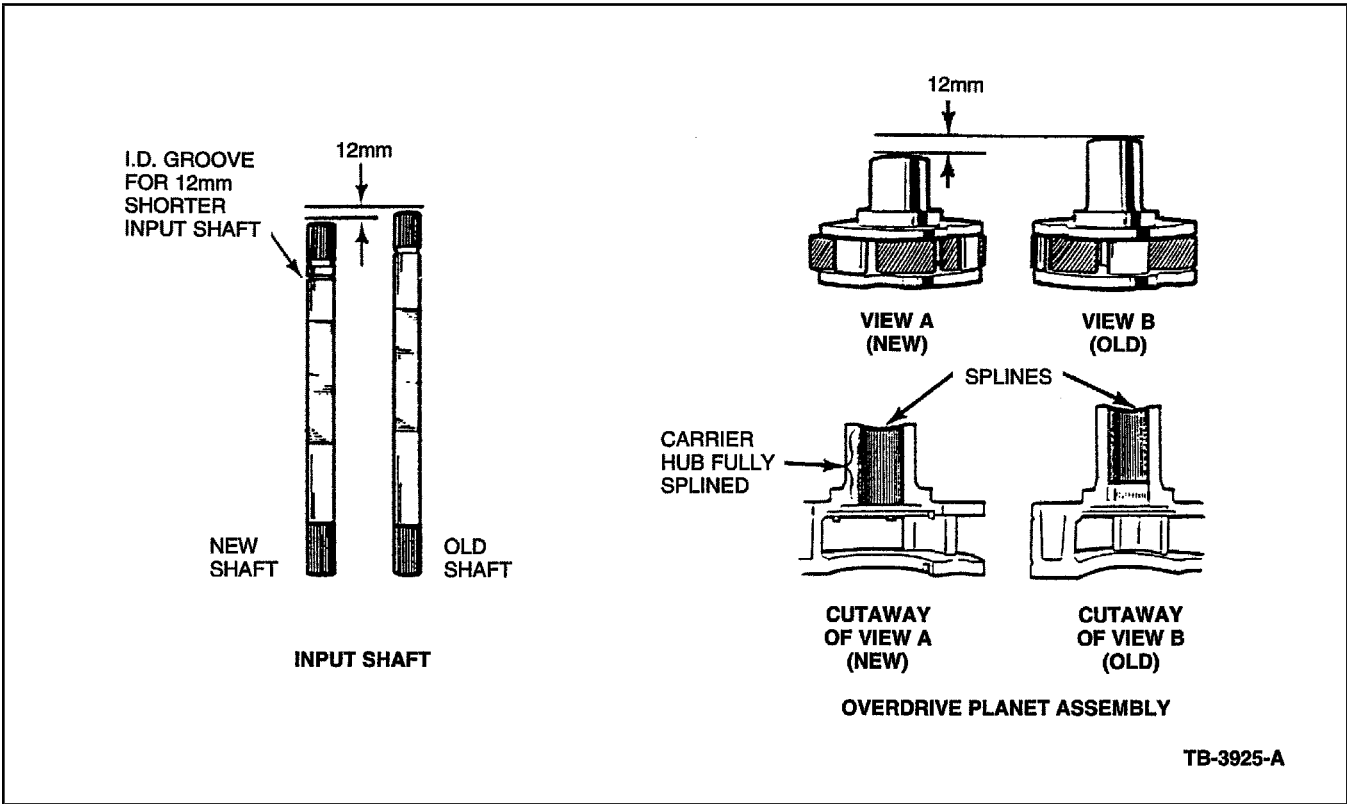

Figure 6 - Article 94-24-15

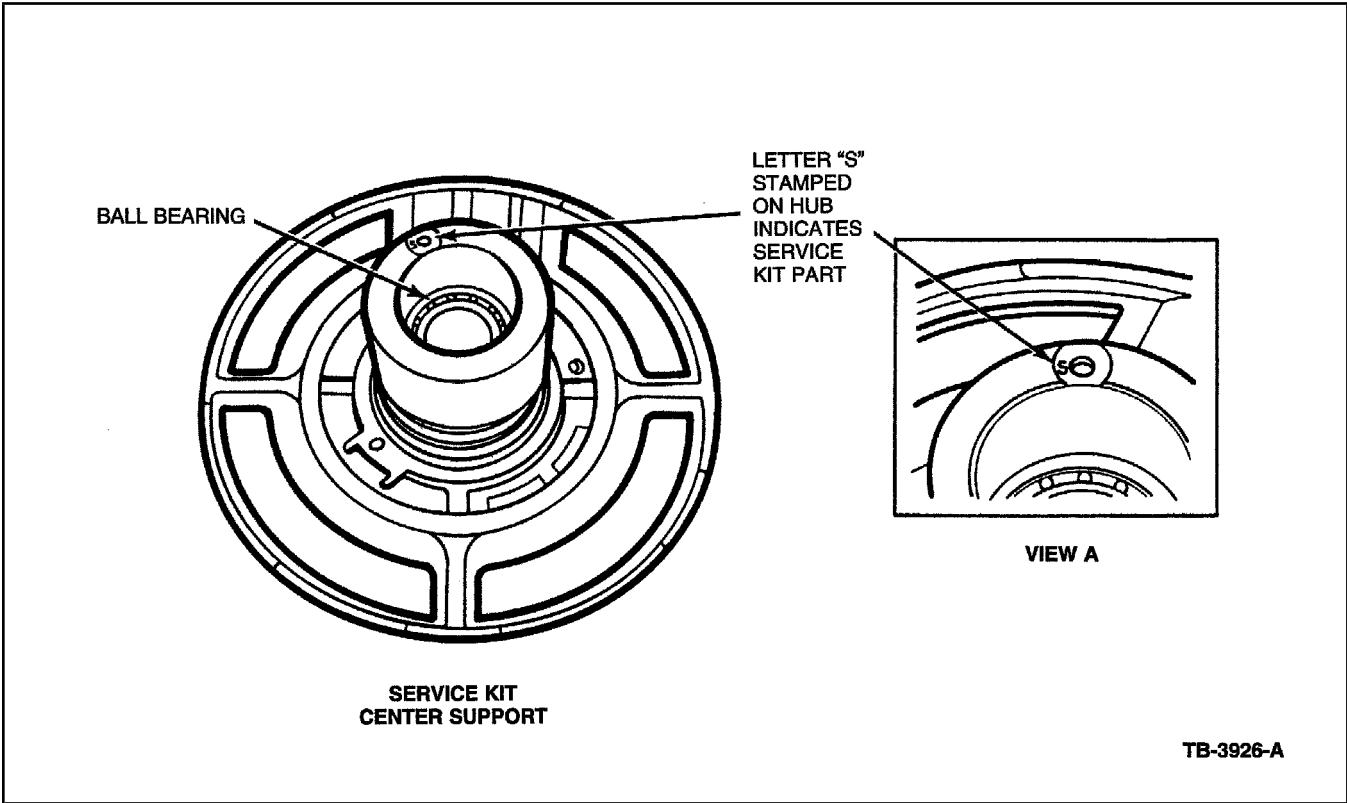
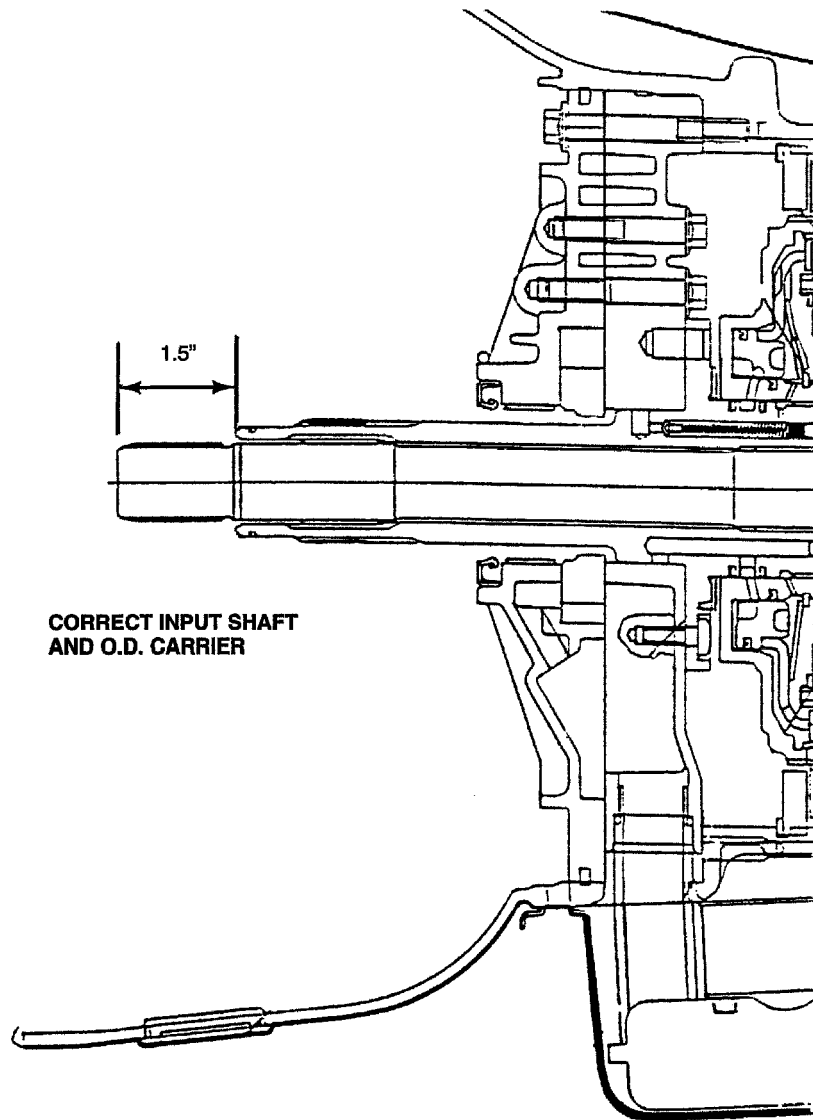

Figure 7 - Article 94-24-15



TB-3927-A

Figure 8 - Article 94-24-15