

Table of contents

Introduction	2
Notice to 4X2 utility vehicle owners	3
4WD and AWD systems	3
4WD Or AWD operation on the road	6
Driving off-road with 4WD or AWD	9
Trailer towing	14
Tires, replacement requirements	15
Maintenance and modifications	17
Hauling cargo and vehicle handling	18
Index	20

Introduction

INTRODUCTION

Welcome to Ford Motor Company's world of four-wheel driving! Your new 4WD or AWD vehicle opens up a completely different and challenging world of travel unlike what you have ever experienced with a conventional two-wheel drive vehicle. Now, you'll be able to travel places where roads don't. You'll be able to travel when weather conditions have made roads impassible for two-wheel drive vehicles. Most importantly, you'll be able to travel with the safety, comfort and dependability of a Ford-built vehicle.

The steering and handling characteristics of vehicles may vary and you must learn and understand the capabilities and limitations of your 4WD or AWD through experience. Take it slow and easy until you get to know and understand your vehicle and have confidence in your ability to drive it.

Your 4WD or AWD vehicle, particularly when loaded, may handle differently than an ordinary passenger car. This is because your vehicle has special design and equipment feature for off-road operation.

Familiarize yourself with this vehicle's operating characteristics. Study the "Owner's Guide" and this supplement for specific information and instructions for safe driving under various conditions.

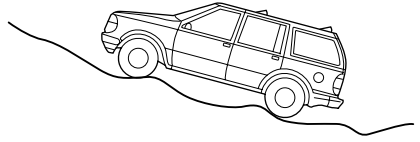

Notice to 4x2 utility vehicle owners

All occupants should always wear the safety belts provided and children/infants should use appropriate restraints to minimize the risk of injury or ejection.

Driving at speeds safe for road conditions and the use of safety belts are the best means of avoiding the possibility of accident and serious injury.

Ford Motor Company reserves the right at any time to change information provided herein, including specifications, design or testing procedures without incurring obligation.

NOTICE TO 4X2 UTILITY VEHICLE OWNERS

Although this supplement is primarily directed to 4WD or AWD vehicle operators, these principles of safe driving also apply to operators of two-wheel drive utility vehicles. Even though you did not select a 4WD or AWD option for your vehicle, many of its operating characteristics are similar to those of 4WD or AWD vehicles. For this reason, Ford urges you to read and understand the contents of this supplement.

4WD AND AWD SYSTEMS

Your AWD or 4WD (when you select the 4WD mode), uses all four wheels to power itself. This increases traction, enabling you to

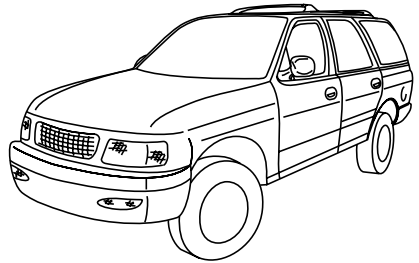

4WD and AWD systems

drive over terrain and road conditions that a conventional two-wheel drive vehicle can't.

Power is supplied to all four wheels through a transfer case. On 4WD vehicles the transfer case allows you to select 4WD when necessary. Information on transfer case operation, shifting procedures and maintenance can be found in your "Owner's Guide." You should become thoroughly familiar with this information before you operate your vehicle.

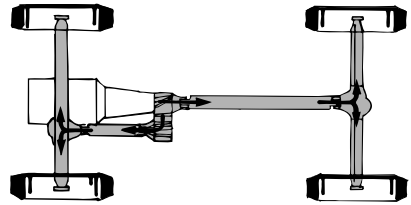

Normal characteristics

- On some 4WD models, the initial shift from two-wheel drive to 4x4 while the vehicle is moving can cause some momentary clunk and ratcheting sounds. This is the front drivetrain coming up to speed and the automatic locking hubs engaging and is not cause for concern.
- On some 4WD models, if the vehicle is stopped while in 4WD and the vehicle direction is reversed from the previous direction, the automatic locking hubs will momentarily disengage and re-engage. The automatic locking hubs may click as they automatically engage in the new direction.

4WD and AWD systems

How your vehicle differs from other vehicles

4WD and AWD vehicles can differ from some other vehicles in a few noticeable ways. Your 4WD or AWD may be:

- Higher — to allow it to travel over rough terrain without getting hung up or damaging underbody components, and to accommodate 4WD components.
- Shorter — to give it the capability to approach inclines and drive over the crest of a hill without getting hung up or damaging underbody components. A shorter wheelbase may make your vehicle quicker to respond to steering inputs than a vehicle with a longer wheelbase.
- Narrower — to provide greater maneuverability in tight spaces, particularly in off-road use.

These differences that make your 4WD or AWD so versatile also make it handle differently than an ordinary passenger car.

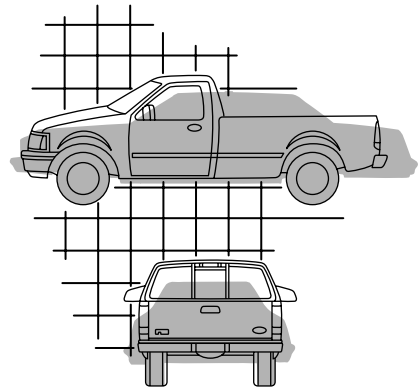
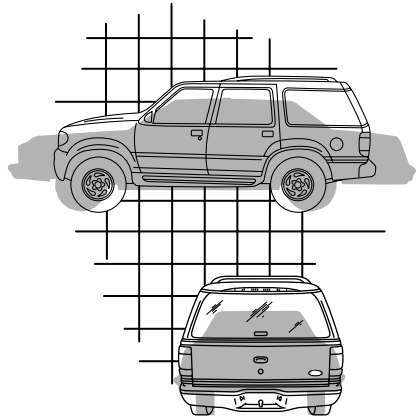

4WD or AWD operation on the road

4WD OR AWD OPERATION ON THE ROAD

Basic operating principles

- Do not use 4WD on dry, hard surfaced roads (except models equipped with Auto 4WD or AWD). This may damage the drivelines and axles.
- Drive slower in strong crosswinds which can affect the normal steering characteristics of your vehicle.
- Be extremely careful when driving on pavement made slippery by loose sand, water, gravel, snow or ice.

If your vehicle goes off the edge of the pavement

- If your vehicle goes off the edge of the pavement, slow down, but avoid severe brake application. Ease the vehicle back onto the pavement only after reducing your speed. Do not turn the steering wheel too sharply while returning to the road surface.
- It may be safer to stay on the apron or shoulder of the road and slow down gradually before returning to the pavement. You may lose control if you do not slow down or if you turn the steering wheel too sharply or abruptly.
- It often may be less risky to strike small inanimate objects, such as highway reflectors, with minor damage to your vehicle

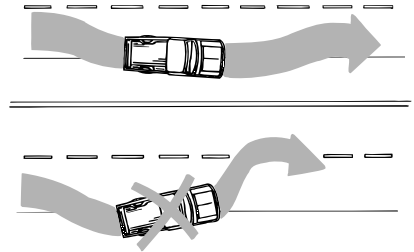

4WD or AWD operation on the road

rather than attempt a sudden return to the pavement which could cause the vehicle to slide sideways out of control or rollover. Remember, your safety and the safety of others should be your primary concern.

Emergency maneuvers

- In an unavoidable emergency situation where a sudden sharp turn must be made, remember to avoid “over-driving” your vehicle, i.e., turn the steering wheel only as rapidly and as far as required to avoid the emergency. Excessive steering will result in less vehicle control, not more. Additionally, smooth variations of the accelerator and/or brake pedal pressure should be utilized if changes in vehicle speed are called for. Avoid abrupt steering, acceleration or braking. Use all available road surface to return the vehicle to a safe direction of travel.
- In the event of an emergency stop, avoid skidding the tires and do not attempt any sharp steering wheel movements.
- If the vehicle goes from one type of surface to another (i.e., from concrete to gravel) there will be a change in the way the vehicle responds to a maneuver (steering, acceleration or braking). Again, avoid these abrupt inputs.

4WD or AWD operation on the road

Snow and ice

Your 4WD or AWD vehicle will have advantages over two-wheel drive vehicles in snow and on ice by providing increased driving traction. However, if you suddenly change speed or direction you may lose control. 4WD and AWD vehicles can slide on slippery roads just like any other vehicle. Should you start to slide while driving on snowy or icy roads, turn the steering wheel in the direction of the slide until you regain control. Avoid sudden braking as well. Although a 4WD or AWD vehicle may accelerate better than a two-wheel drive vehicle in snow and ice, it won't stop any faster, because as in other vehicles, braking occurs at all four wheels. Do not become overconfident as to road conditions.

Make sure you allow sufficient distance between you and other vehicles for stopping. In emergency stopping situations, avoid locking of the wheels. Use a "squeeze" technique, push on the brake pedal with a steadily increasing force which allows the wheels to brake yet continue to roll so that you may steer in the direction you want to travel. If you lock the wheels, release the brake pedal and repeat the squeeze technique. If your vehicle has anti-lock brakes, apply the brake steadily. Do not "pump" the brakes. See your "Owner's Guide" for additional information on the

Driving off-road with 4WD or AWD

operation of the anti-lock brake system.

Parking

Before leaving the driver's seat, you should make sure that the gearshift is engaged in P (Park) with an automatic transmission or either 1 (First) or R (Reverse) with a manual transmission. Set the parking brake fully, shut off the ignition and remove the key.

On some 4WD vehicles, when the transfer case is in the N (Neutral) position, the engine and transmission are disconnected from the rest of the driveline.

Therefore, the vehicle is free to roll even if the automatic transmission is in P (Park) or the manual transmission is in gear. Do not leave the vehicle unattended with the transfer case in N (Neutral) position. Always set the parking brake fully and turn off the ignition when leaving the vehicle.

DRIVING OFF-ROAD WITH 4WD OR AWD

When using 4WD or AWD, maintain steering wheel control at all times, especially in rough terrain. Since sudden changes in terrain can result in abrupt steering wheel motion, make sure you grip the steering wheel from the outside. Do not grip the spokes.

Driving off-road with 4WD or AWD

Drive cautiously to avoid vehicle damage from concealed objects such as rocks and stumps. You should either know the terrain or examine maps of the area before driving. Map out your route before driving in the area. To maintain steering and braking control of your vehicle, you must have all four wheels on the ground and they must be rolling, not sliding or spinning.

Sand

When driving over sand, try to keep all four wheels on the most solid area of the trail. Avoid reducing the tire pressure. Instead, shift to a lower gear and drive steadily through the terrain. Apply the accelerator slowly and avoid spinning the wheels.

If you must reduce the tire pressure for whatever reason in sand, make sure you re-inflate the tires as soon as possible.

Avoid excessive speed because vehicle momentum can work against you and cause the vehicle to become stuck to the point that assistance may be required from another vehicle. Remember, you may be able to back out the way you came if you proceed with caution.

Mud

Be cautious of sudden changes in vehicle speed or direction when you are driving in mud. Even 4WD

Driving off-road with 4WD or AWD

and AWD vehicles can lose traction in slick mud. As when you are driving over sand, apply the accelerator slowly and avoid spinning your wheels. If the vehicle does slide, steer in the direction of the slide until you regain control of the vehicle.

After driving through mud, clean off residue stuck to rotating driveshafts and tires. Excess mud stuck on tires and rotating driveshafts causes an imbalance that could damage vehicle components.

“Tread Lightly” is an educational program designed to increase public awareness of land-use regulations and responsibilities in our nations wilderness areas. Ford joins the U.S. Forest Service and the Bureau of Land Management in encouraging you to help preserve our national forest and other public and private lands by “treading lightly.”



Driving off-road with 4WD or AWD

Water

Before driving through water, determine the depth. Avoid water higher than the bottom of the wheel hubs. Proceed slowly to avoid splashing, if the ignition system gets wet, the vehicle may stall.

Once through water, always try the brakes. Wet brakes do not stop the vehicle as effectively as dry brakes. You can dry the brakes faster by driving the vehicle slowly while applying light pressure on the brake pedal.



Deep snow

4WD and AWD vehicles are unique in that they can be driven in deep snow that would stop a conventional two-wheel drive vehicle. Shift to a low gear and maintain steady pressure on the accelerator. This will help prevent spinning the wheels while maintaining sufficient momentum to keep from bogging down. Using tire chains will also help.

Never drive with chains on the front tires of 4WD or AWD vehicles without also putting them on the rear tires. This could cause the rear to slide and swing around during braking.

Driving on hills

Although natural obstacles may make it necessary to travel

Driving off-road with 4WD or AWD

diagonally up or down a hill or steep incline, you should always try to drive straight up or straight down. **Avoid driving crosswise or turning on steep slopes or hills.** A danger lies in losing traction, slipping sideways and possibly rolling over. Whenever driving on a hill, determine beforehand the route you will use. Do not drive over the crest of a hill without seeing what conditions are on the other side. Do not drive in reverse over a hill without the aid of an observer.

When climbing a steep slope or hill, start in a lower gear rather than downshifting to a lower gear from a higher gear once the ascent has started. This reduces strain on the engine and the possibility of stalling.

If you do stall out, Do not try to turnaround because you might roll over. It is better to back down to a safe location.

Apply just enough power to the wheels to climb the hill. Too much power will cause the tires to slip, spin or lose traction, resulting in loss of vehicle control.

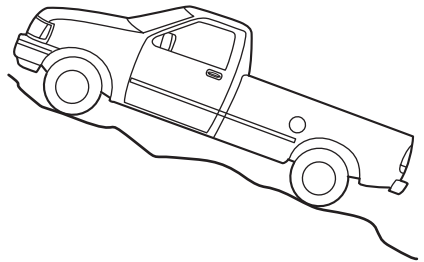

Trailer Towing

Descend a hill in the same gear you would use to climb up the hill to avoid excessive brake application and brake overheating. Do not descend in neutral, disengage overdrive or manually shift to a lower gear. When descending a steep hill, avoid sudden hard braking as you could lose control. When you brake hard, the front wheels can't turn and if they aren't turning, you won't be able to steer. The front wheels have to be turning in order to steer the vehicle. Rapid pumping of the brake pedal will help you slow the vehicle and still maintain steering control.

If your vehicle has anti-lock brakes, apply the brakes steadily. Do not "pump" the brakes.

TRAILER TOWING

Your 4WD or AWD vehicle may be equipped for towing trailers (or may require a trailer tow package), provided that the combined total weight of the vehicle and trailer is less than or equal to the recommended Gross Combination Weight Rating (GCWR). Refer to "Ford Recreation Vehicle and Trailer Towing Guide," the "Owner's Guide" or see an authorized Ford or Lincoln/Mercury Dealer for additional information.

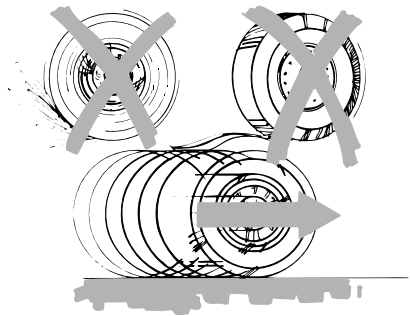

Tires, replacement requirements

TIRES, REPLACEMENT REQUIREMENTS

Your 4WD or AWD vehicle is equipped with tires designed to provide for safe ride and handling capability.

Do not use a size and type of tire and wheel other than that originally provided by Ford because it can affect the safety and performance of your vehicle, which could lead to loss of vehicle control or rollover and serious injury. Make sure all tires and wheels on the vehicle are of the same size, type, tread design, brand and load-carrying capacity. If you have questions regarding tire replacement, see an authorized Ford or Lincoln/Mercury dealer.

If you nevertheless decide to equip your 4WD or AWD for off-road use with tires larger than what Ford recommends, you should not use these tires for highway driving.

If you use any tire/wheel combination not recommended by Ford, it may adversely affect vehicle handling and could cause steering, suspension, axle or transfer case failure.

Do not use "aftermarket lift kits" or other suspension modifications, whether or not they are used with larger tires and wheels.

These "aftermarket lift kits" could adversely affect the vehicle's handling characteristics, which could lead to loss of vehicle

Tires, replacement requirements

control or rollover and serious injury.

Tires can be damaged during off-road use. For your safety, tires that are damaged should not be used for highway driving because they are more likely to blow out or fail.

You should carefully observe the recommended tire inflation pressure found on the safety compliance certification label attached to the left front door lock facing or door latch post pillar. Failure to follow tire pressure recommendations can adversely affect the way your vehicle handles. Do not exceed the Ford recommended pressure even if it is less than the maximum pressure allowed for the tire.

Each day before you drive, check your tires. If one looks lower than the others, use a tire gauge to check pressure of all tires, and adjust if required. Check tire pressure with a tire gauge every few weeks (including spare). Safe operation requires tires that are neither underinflated nor overloaded.

Periodically inspect the tire treads and remove stones, nails, glass or other objects that may be wedged in the tread grooves. Check for holes or cuts that may permit air leakage from the tire and make necessary repairs.

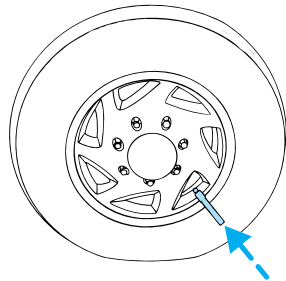

Maintenance and modifications

Inspect the tire side walls for cuts, bruises and other damage. If internal damage to the tire is suspected, have the tire demounted and inspected in case it needs to be repaired or replaced.

MAINTENANCE AND MODIFICATIONS

The suspension and steering systems on your vehicle have been designed and tested to provide both reasonably safe, predictable performance whether loaded or empty and durable load carrying capability. For this reason, Ford strongly recommends that you do not make modifications such as adding or removing parts (such as lift kits or stabilizer bars) or by using replacement parts not equivalent to the original factory equipment.

Any modifications to a vehicle that raise the center of gravity can make it more likely the vehicle will roll over as a result of a loss of control. Ford recommends that caution be used with any vehicle equipped with a high load or device (such as ladder racks or pickup box cover).

Failure to maintain your vehicle properly may void the warranty, increase your repair cost, reduce vehicle performance and operational capabilities and adversely affect driver and passenger safety. Frequent inspection of vehicle chassis

Hauling cargo and vehicle handling

components is recommended if the vehicle is subjected to heavy off-road usage. Refer to the “Owner’s Guide” and “Service Guide” for proper maintenance instructions and schedules.

HAULING CARGO AND VEHICLE HANDLING

When using your vehicle to haul cargo, make sure it is properly loaded to help ensure safe handling. Cargo should be evenly distributed over the floor of the cargo area, with the heaviest cargo on the bottom and ahead of the rear axle.

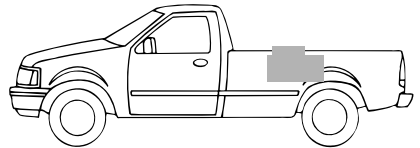
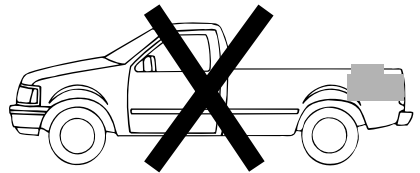

If you must haul cargo on the roof of the vehicle, use extra caution when driving. Cargo placed on the roof will tend to make your vehicle top heavy, causing it to lean more on corners and creating a greater possibility of vehicle roll over should you lose control of the vehicle.

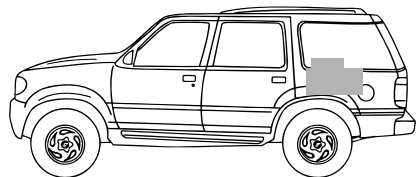
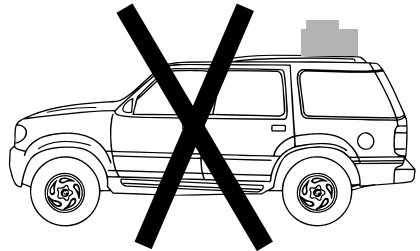

Hauling cargo and vehicle handling

Loading the vehicle improperly can deteriorate handling capability and contribute to loss of vehicle control.

Once you have reached the weight capacity of the vehicle, do not add more cargo, even if there is space available. Make sure you consult the safety compliance certification label attached to your vehicle and the “Owner’s Guide” for information on maximum safe vehicle weight limits.

Index

All-Wheel Drive System, The	3	Lift Kits	15
AWD Vehicle Operation	6	Maintenance and Modifications ..	17
Cargo, Hauling and Vehicle		Mud, Driving in	10
Handling	18	Off-Road Driving	9
Differences in Four-Wheel		Operating Your AWD Vehicle	
Drive	5	on the Road	6
Driving Off-Road with 4WD	9	Operating Your Four-by-Four	
Driving Off-Road with AWD	9	on the Road	6
Emergency Maneuvers	7	Parking	9
Four-by-Four Operation	6	Sand, Driving in	10
Four-Wheel Drive System, The ...	3	Snow, Deep, Driving in	12
Hauling Cargo and Vehicle		Snow/Ice, Driving in	8
Handling	18	Tires, Replacement	
Hills, Driving on	12	Requirements	15
If Your Vehicle Goes Off the		Trailer Towing	14
Edge of the Pavement	6	Water, Driving in	12
Introduction	2		